

# User Manual

## Marine Watch S Series

S-ONE Alarm Panel  
S-ACE Annunciator Panel  
I/O Cabinet



# Auto MASKIN

## Table of contents

<b>1 About this Manual.....</b>	<b>3</b>		
1.1 Intended Audience.....	3		
1.2 Responsibilities.....	3		
1.3 Revisions.....	3		
<b>2 System Overview.....</b>	<b>4</b>		
2.1 Introduction to Marine Watch.....	4		
2.2 Typical Installation.....	5		
2.3 Components and Default IP Address.	5		
2.4 Marine Watch S Component Description.....	8		
2.5 S-ONE Main Panel Emergency Switchover.....	11		
2.6 Periodically Unattended Engine Room. 12			
2.7 USB-port.....	17		
2.8 Cyber Security.....	17		
<b>3 The S-ONE User Interface.....</b>	<b>21</b>		
3.1 Header Information.....	21		
3.2 The Home Page.....	22		
3.3 The Alarm List.....	23		
3.4 The Channel Pages.....	26		
3.5 Screen Navigation.....	34		
<b>4 The S-ONE Main Menu.....</b>	<b>35</b>		
4.1 Attendance.....	35		
4.2 Controls.....	36		
4.3 Display.....	38		
4.4 Event Log.....	40		
4.5 Troubleshooting.....	42		
		4.6 Administration.....	44
<b>5 The S-ONE Administration Menu.....</b>	<b>47</b>		
5.1 This Panel.....	47		
5.2 System.....	52		
5.3 Switch Channels.....	56		
5.4 Analog Channels.....	57		
5.5 Engine Channels.....	60		
5.6 Output Channels.....	61		
5.7 Group Channels.....	65		
5.8 Conditions.....	66		
5.9 Maintenance.....	67		
<b>6 The S-ACE Annunciator Panel.....</b>	<b>70</b>		
6.1 Buttons.....	70		
6.2 Header Information.....	70		
6.3 Header Status Symbols.....	71		
6.4 Alarm View.....	71		
6.5 Menu.....	73		
<b>7 I/O Cabinet.....</b>	<b>82</b>		
7.1 Power Supply.....	82		
7.2 Ethernet Communication.....	82		
7.3 Switch Channels.....	82		
7.4 Analog Channels.....	83		
7.5 Output Channels.....	85		
7.6 Supply for Auxiliary Equipment.....	86		
<b>8 Engine Cabinet.....</b>	<b>87</b>		
8.1 Wiring.....	87		

## 1 About this Manual

### 1.1 Intended Audience

This manual has been published primarily for professionals and qualified personnel. Its user is assumed to have basic knowledge of marine systems and can carry out related electrical work.



Work on the low-voltage circuit should only be carried out by qualified and experienced personnel.

Installation or work on the shore power equipment *must only* be carried out by electricians authorised to work with such installations.

### 1.2 Responsibilities

It is the **installer's sole responsibility** to ensure that the installation work is carried out satisfactorily, that it is operationally in good order, that the approved material and accessories are used and that the installation meets all applicable rules and regulations.



Auto-Maskin continuously upgrades its products and reserves the right to make changes and improvements without prior notice.

All information in this manual is based upon information at the time of printing. For updated information, please contact your local distributor.



The crossed-out wheeled bin symbol indicates that the item should be disposed of separately. The item should be handed in for recycling in accordance with local environmental regulations for waste disposal.

Separating a marked item will help reduce the volume of waste sent to incinerators or landfills and minimise any potential negative impact on human health and the environment.

### 1.3 Revisions

This manual is valid for the latest software version of the Marine Watch S Series Alarm Panel.

#### 1.3.1 Software revisions

- See [this document](#) for S-ONE Alarm Panel software revisions.
- See [this document](#) for S-ACE Annunciator Panel software revisions.

### 1.3.2 User Manual Revision

User manual revision: March 3, 2026

## 2 System Overview

### 2.1 Introduction to Marine Watch

The Marine Watch S Series is a sophisticated and powerful alarm system designed to be easy to set up and use.

The S-ONE Alarm Panel touchscreen displays binary events as rectangles, where each rectangle represents the status of a channel. Analog channels are represented with gauges.

In the event of a warning or an alarm, the corresponding rectangle indicates clearly with a flashing behaviour and the buzzer sounds. An operator can acknowledge the event by touching the rectangle.

Additional S-ONE Alarm Panels can be added to the network, and these are designated Subpanels. Finally, several S-ACE Annunciator Panels can be added to the network.

All I/O interfaces are built into a separate I/O Cabinet. Communication between the Alarm Panel and the I/O Cabinet is standard Ethernet.

The optional engine interface is accomplished using either stand-alone Engine Cabinets or an already installed Marine Pro system.

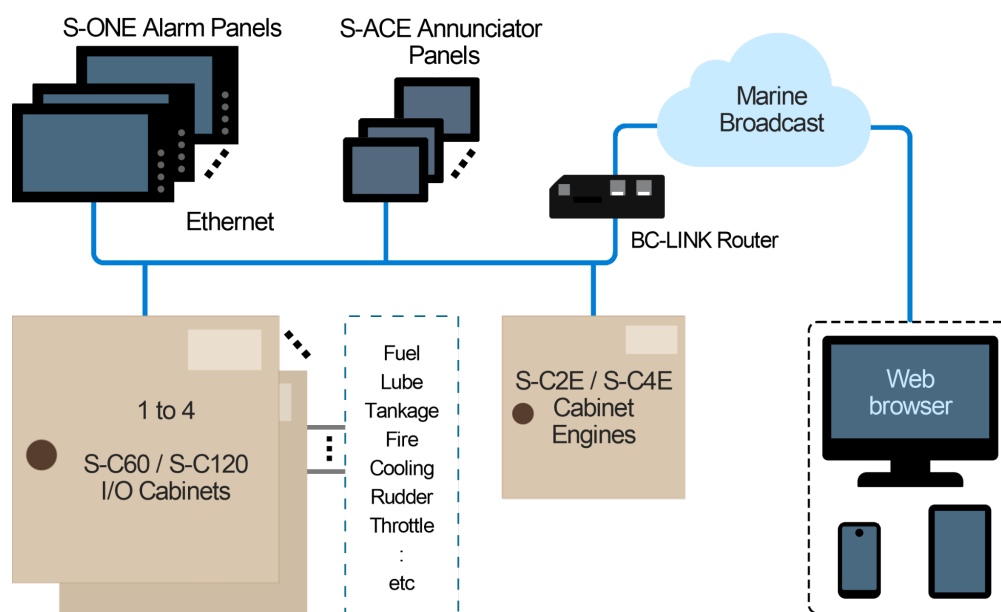

The optional Marine Broadcast is a secure cloud-based remote monitoring service for connected vessels, accessible from any device.

The BC-LINK Router can be used to enable Internet access, if needed.

Scan the QR code to learn more and get started with Marine Broadcast, or visit

[auto-maskin.com/broadcast-getting-started](http://auto-maskin.com/broadcast-getting-started)



## 2.2 Typical Installation

The typical Marine Watch installation consists of one or several I/O Cabinets, one or several S-ONE Alarm Panels, and a few S-ACE Annunciator Panels. All units are connected to a standard Ethernet network.

Additional S-ONE and S-ACE panels can be added at any time and require no change in the overall configuration. One must only make sure there is no IP address conflict.

The S-ONE Alarm Panel can be used as either the Main Panel or a Subpanel.

## 2.3 Components and Default IP Address

All Marine Watch S Series components have a factory-default IP address. If more than one of each type of component is in use, then make sure to change the IP address of the extra component.

No two components in the network shall have the same IP address.

### 2.3.1 Main Panel

In the configuration, one of the S-ONE alarm panels shall be designated the Main Panel. This is the default configuration.

The Main Panel, which holds the entire system configuration, shall be configured. The configuration is done in the Administration submenu.

Configuration can be done manually using the panel menu interface or by loading a predefined configuration file.

**Note!** Ethernet 1 default IP address: 192.168.0.151





Configuration changes are automatically applied to all networked Subpanels and Annunciator panels.

### 2.3.2 Subpanels

Additional S-ONE alarm panels can be added to the network, and these are called Subpanels. It must be configured as such under Panel Type in the Administration menu.

Each Subpanel replicates the Main Panel and optionally has specific use cases.

A Subpanel is automatically always in sync with the Main Panel configuration.

**Note!** Ethernet 1 default IP address: 192.168.0.151<sup>1</sup>



### 2.3.3 Annunciator Panels

Several S-ACE annunciator panels can be added to the network.

An annunciator panel is automatically always in sync with the S-ONE Main Panel configuration.

**Note!** Default IP address: 192.168.0.201<sup>2</sup>

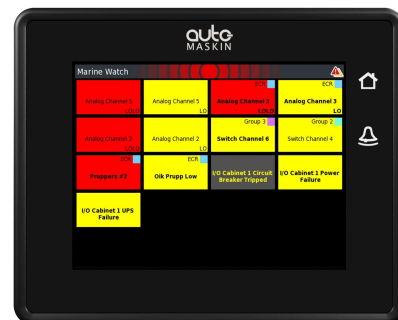

### 2.3.4 I/O Cabinet

The I/O Cabinet is the sensor hub. It collects all sensor data and makes it available to the Marine Watch Panels.

The I/O Cabinet is available in different sizes, I/O capacities, and I/O types.

There can be up to four I/O cabinets in the network.

**Note!** Default IP address: 192.168.0.11<sup>3</sup>



<sup>1</sup> From the factory, the IP address on the Subpanel is the same as for the Main Panel. This must be changed so that all networked panels have a unique address.

<sup>2</sup> If several S-ACE Annunciator Panels are in use, then make sure all IP addresses are unique.

<sup>3</sup> If several I/O Cabinets are in use, then make sure all IP addresses are unique.

### 2.3.5 Engine Cabinet

The Engine Cabinet is the interface to the engine network.

The Engine Cabinet can support up to 4 engines.

**Note!** Default IP address: 192.168.0.101<sup>4</sup>

See an overview of engine cabinet types [here](#).

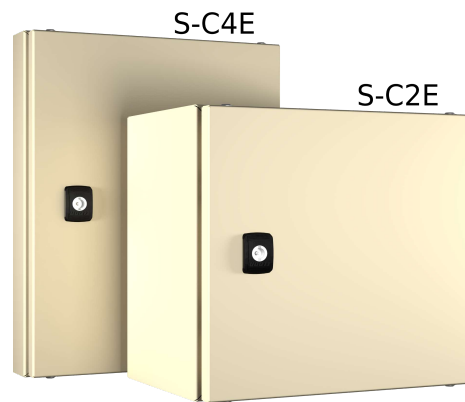

---

<sup>4</sup> If the Engine Cabinet contains 2 DCU engine controllers, make sure the IP addresses are unique.

## 2.4 Marine Watch S Component Description

### 2.4.1 S-ONE Alarm Panel

#### 2.4.1.1 Connectivity and Interfaces

The rear underside of the S-ONE Alarm Panel has all the interfaces.

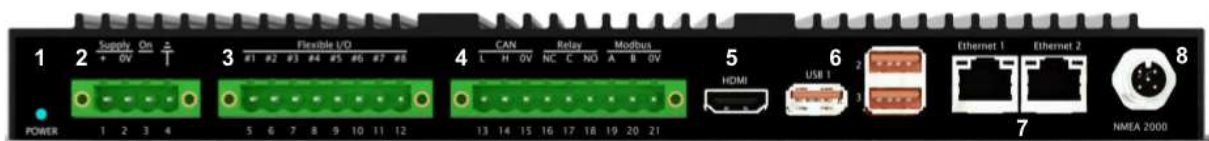

1	<b>Power LED</b>
2	<b>Power supply</b> 1. +12/24 V 2. 0 V 3. Power on <sup>6</sup> 4. Gnd
3	<b>Flexible I/O</b> 5. I/O #1 6. I/O #2 7. I/O #3 8. I/O #4 9. I/O #5 10. I/O #6 11. I/O #7 12. I/O #8
4 <sup>7</sup>	<b>CAN bus, Relay, Modbus RTU</b> 13. CAN L 14. CAN H 15. CAN 0V 16. Relay NC 17. Relay C 18. Relay NO 19. Modbus A 20. Modbus B 21. Modbus 0V

5 <sup>5</sup>	<b>HDMI</b>
6	<b>USB-A (2.0 High-speed interface)</b> • USB 1 • USB 2 • USB 3  Reserved for software update, event log extraction, and configuration file handling
7	<b>Ethernet</b> • Ethernet 1, RJ45 • Ethernet 2, RJ45  Ethernet 1 is preferred for networking.
8 <sup>8</sup>	<b>NMEA 2000 – isolated</b>

<sup>5</sup> Not in use

<sup>6</sup> Not in use, connect to 24V for future use

<sup>7</sup> Not in use

<sup>8</sup> Not in use

Miscellaneous	
Buzzer	Activates for any new event.
Ambient Light Sensor	Automatic adjustment of screen brightness.
Proximity Sensor	Motion detection.

### 2.4.1.2 Operator Interface

In addition to the touch interface on the screen, there are buttons on the right-hand side of the panel. These are used to control different parts of the panel as described below:

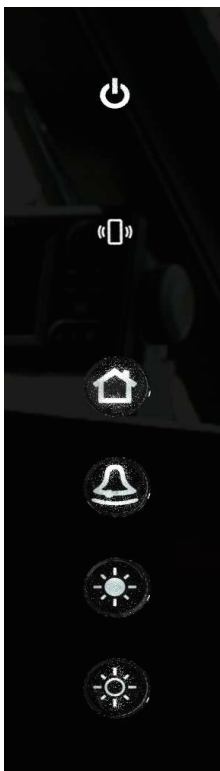

Interface	
Power Indication	Lit when the panel is powered.
NFC Sensor	Not used in this software revision.
Home Button	The Home button displays the Home page. When on the Home page, the home button displays the previous instrument page. A long press displays the Menu page.
Alarm Button	Silences the buzzer and displays the alarm list. When displaying the alarm list and pressing the Alarm button <ul style="list-style-type: none"> <li>• If the buzzer is sounding the buzzer will be silenced</li> <li>• If no buzzer is sounding the previous page will be displayed</li> </ul>
Brightness Increase Button	Increase screen brightness.
Brightness Decrease Button	Decrease screen brightness.

### 2.4.1.3 Communication Interface

Other systems can interface with the S-ONE Alarm Panel using the built-in Modbus TCP interface on Ethernet.

The communication I/O list can be found here: <http://tiny.cc/zxxebz>

## 2.4.2 S-ACE Annunciator Panel

### 2.4.2.1 Connectivity and Interfaces





Connectivity	
Description	Connector
Power Typical: 0.4 A @ 24 V	C1.11: +12/24 V C1.12: 0 V
External Buzzer Max: 0.2 A	C1.1 0 V at C1.12 or other 0 V.
Ethernet	RJ 45
USB	USB-A

For full information of the connectivity and interfaces, see the datasheet of the product. In order to achieve full IP-56 ingress support, the unused connectors must be populated with sealing plugs<sup>9</sup>.

### 2.4.2.2 Operator Interface

In addition to the touch interface on the screen, there are buttons on the right-hand side of the panel. These are used to control different parts of the panel as described below:

Symbol	Button	Action
	Home Button	Toggles between the Alarm list and Menu page.
	Alarm Button	Silences the buzzer and displays the Alarm list.

<sup>9</sup> SKU: 1006946. Extend with external buzzer (SKU: 1500736) if needed

### 2.4.3 I/O Cabinet

Marine Watch includes a standard set of signals in the I/O Cabinet. For further details, see the [I/O Cabinet](#) chapter.

I/O Cabinet Type	Description
S-C60	Base cabinet supporting up to 60 switch channels.
S-C120	Base cabinet supporting up to 120 switch channels.



The I/O Cabinet can be extended with analog channels or output channels.

### 2.4.4 Engine Cabinet

The Engine Cabinet provides an interface to the engine network. It is an optional interface component that enables an overview of up to 2 propulsion and 2 genset engines. See the [Engine Cabinet](#) chapter.

Engine Cabinet Type	Description
S-C2E	Supports two engine interfaces, propulsion or genset.
S-C4E	Support four engine interfaces, propulsion or genset. A maximum of two propulsion and 2 genset interfaces.

## 2.5 S-ONE Main Panel Emergency Switchover

In the unlikely event of a Main Panel failure, any Subpanel can act as a replacement panel and can quickly be reconfigured as a Main Panel.

Make the system operative again:

1. Remove the Ethernet cable from the faulty Main Panel.
2. In the **Administration menu** of the desired replacement panel, select **This Panel > Panel Type: Select Main Panel**.
3. On the same administrative page, take note of the **replacement panel** IP address.

Reconnect any other Subpanels and Annunciator Panels.

4. If the Marine Watch S system consists of additional S-ONE Subpanels or S-ACE Annunciator Panels, they must be reconfigured. In the **Administration menu**, select **I/O Cabinet > Network**: Enter the **replacement panel** IP address.



Ensure only one panel is configured as the **Main Panel** in the Marine Watch S system.

## 2.6 Periodically Unattended Engine Room

The Marine Watch S Series system supports periodically unattended engine room installations.

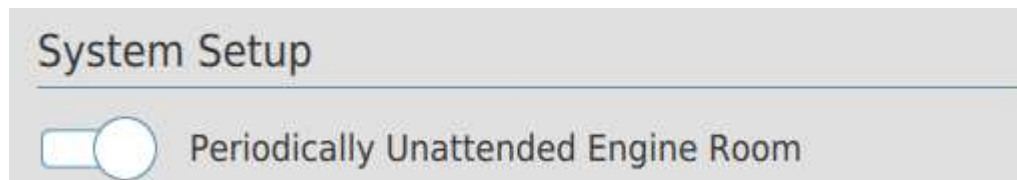

The minimum setup for a periodically unattended engine room installation is the following

- S-ONE Main Panel in the engine room / engine control room
- S-ACE or S-ONE Subpanel on the bridge
- S-ACE or S-ONE Subpanel in the engineers cabin



When the engine room is unattended, any alarm condition in the main alarm system shall initiate an alarm in the duty engineers' cabin and in all public spaces the duty engineer may reside.

This can be accomplished by installing an S-ACE or S-ONE Subpanel in such locations.

### 2.6.1 Watch Responsibility and Watch Transfer

When the engine room is attended, the engineer in the engine room has the watch responsibility. The watch responsibility can be transferred to and from the bridge using the Marine Watch S Series panels.

When a successful watch transfer to the bridge has been executed, the bridge has the watch responsibility, and the engine room can be left unattended.

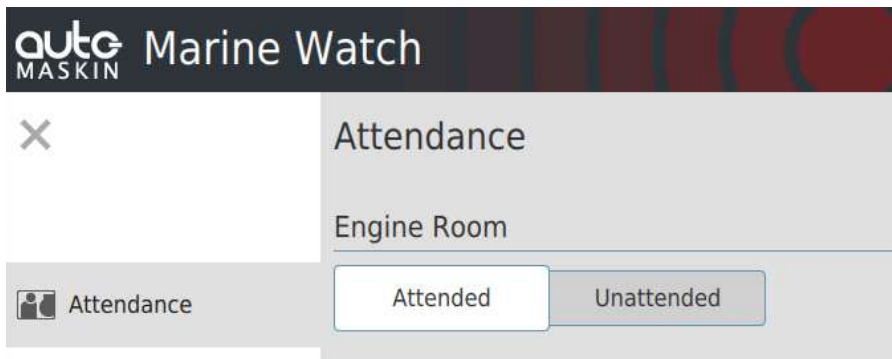

### 2.6.1.1 Watch Responsibility Indication

This symbol is shown in the panel header when the panel has watch responsibility.





If the engine room has watch responsibility, this is equivalent to an attended engine room. Likewise, if the bridge has watch responsibility, the engine room can be unattended.

In addition, engine room status (attended / unattended), as well as an on-duty engineer (in case of unattended engine room), can be inspected using the panel menu.

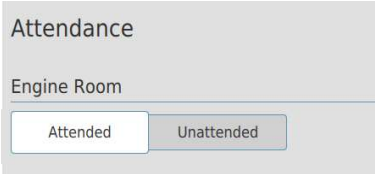
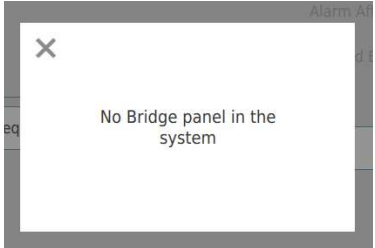
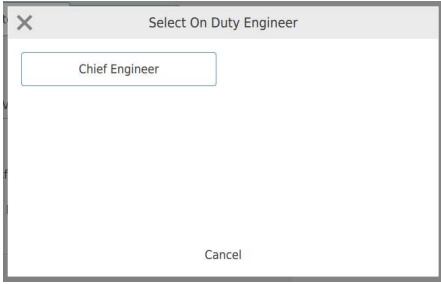

### 2.6.1.2 Watch Transfer to Bridge

When the engine room engineer is about to leave the engine room, the engineer must transfer watch responsibility to the bridge before leaving.

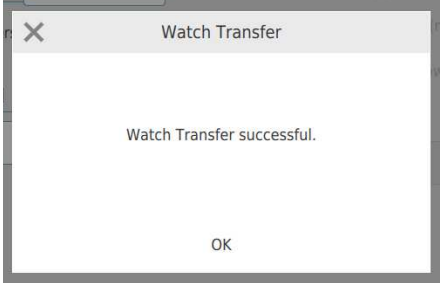
<p>Request unattended on the Engine Room panel or the Engine Control Room panel by pressing the <b>Unattended</b> button.</p>	
<p>If no Bridge panel exists in the system, this is indicated with a popup and the transfer request is aborted.</p>	
<p>Select which "Engineers Cabin" shall be "On duty".  If no Engineers Cabin panel exists in the system, this is indicated with a popup and the transfer request is aborted.</p>	
<p>Audible sound and dialog on all Bridge panels.</p>	
<p>If the bridge accepts the transfer, watch transfer is performed, and the bridge has the watch responsibility.</p>	

If the bridge denies the transfer (or times out), no watch transfer has been performed, and the engine room still has watch responsibility.

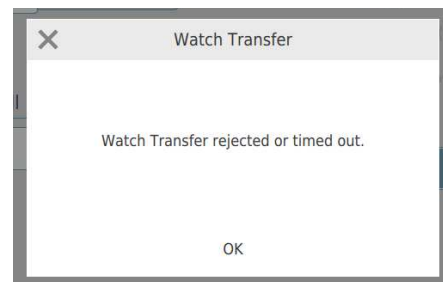

### 2.6.1.3 Watch Transfer to Engine Room

When the engine room engineer enters the engine room, the engineer takes watch responsibility, and the bridge panel is informed.

Request attended on the Engine Room panel or the Engine Control Room panel by pressing the **Attended** button.

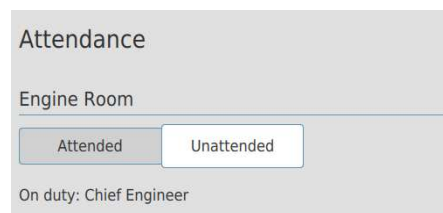

Dialogue on all Bridge panels.

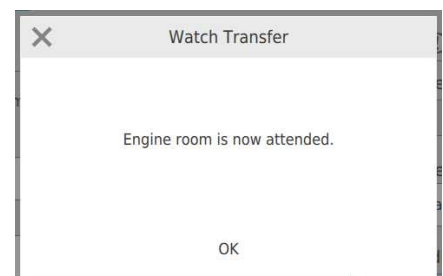

### 2.6.2 Buzzer and Acknowledge

Depending on the panel location, the buzzer activates according to the following table.

Location	Attended Engine Room	Unattended Engine Room
Bridge	Per group configuration	Activate buzzer
Engineers cabin [on duty]	Silent	Activate buzzer

Location	Attended Engine Room	Unattended Engine Room
Engineers cabin [off duty]	Silent	Silent <sup>10</sup>
Other / Public spaces	Silent	Activate buzzer
Engine room	Activate buzzer	Activate buzzer
Engine control room	Activate buzzer	Activate buzzer

The Marine Watch S Series panels installed on the bridge can be configured to which channel groups shall activate the buzzer in an attended engine room situation.

This can be used to minimise the potential disturbance on the bridge when the engine room is attended.

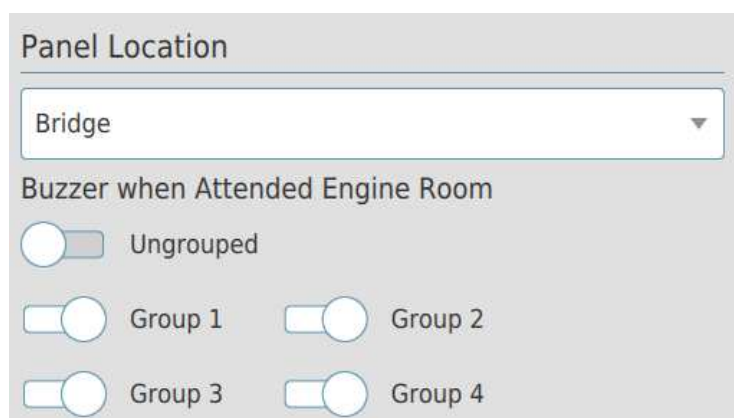

### 2.6.2.1 Engine Room / Engine Control Room

The S-ONE Main Panel should be configured to acknowledge all events. If an S-ONE Subpanel is installed in the engine room, in addition to the S-ONE Main Panel, it can be configured to acknowledge events as well as perform a system-wide silence.

Silencing the buzzer on one of these panels will silence all buzzers in the Marine Watch S Series system.

### 2.6.2.2 Other Locations

Panels in other locations shall not be able to acknowledge events. The S-ACE panels can not acknowledge any events, whereas the S-ONE Subpanels can be configured to not acknowledge events.

<sup>10</sup> Engineers Alarm will activate the buzzer on the off duty engineers cabin as well.

Silencing the buzzer on one of these panels only silences the local buzzer. A local silence does not affect the buzzer in all other locations.

### 2.6.3 Engineers Alarm

The Engineers Alarm can be configured on the Main Panel.

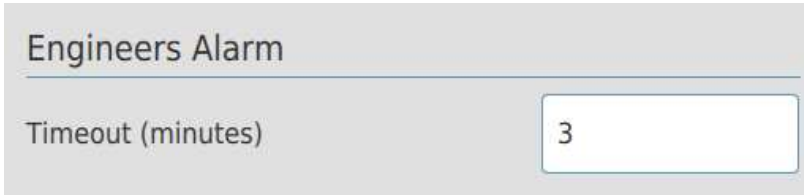

Engineers Alarm

Timeout (minutes)

If an event is not acknowledged within the configured time (1 - 10 minutes), the Engineers Alarm will activate. The Engineers Alarm will activate all panel buzzers (including any panel in the off-duty engineers cabin).

## 2.7 USB-port

The USB ports of the Marine Watch S-ONE and S-ACE panels are used for software update, extraction of log files and applying a configuration. The following file systems are supported on the USB flash drive.

USB File System	S-ONE	S-ACE
FAT32	X	X
exFAT	X	-
NTFS	X	-

## 2.8 Cyber Security

This chapter describes the configuration required and any input to a potential Cyber Security Management System in order to comply with IACS's cyber security regulations.



The Marine Broadcast remote monitoring solution can be used but is not covered by the Marine Watch S type approval certificates.

### 2.8.1 Configuration to Comply

The following is required to comply with cyber security requirements.

### 2.8.1.1 Marine Watch S-ONE and S-ACE

#### 2.8.1.1.1 Required Configuration

- SSH shall be disabled, which is the default for factory-produced units.

#### 2.8.1.1.2 Recommended Configuration

- Change the PIN code to something which is not the default.

#### 2.8.1.1.3 Inspect Configuration

The configuration can be inspected in the Administrative part of the menu.

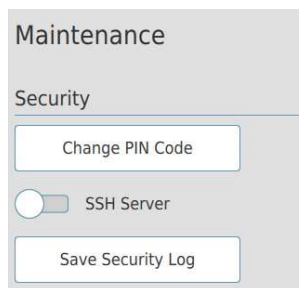

### 2.8.1.2 Marine Watch S I/O Cabinet

If the Marine Watch S I/O Cabinet contains a managed Ethernet switch, Auto-Maskin supplies this switch in a factory default state. The switch needs to be configured according to the following

1. The administrative password needs to be configured
2. Unused protocols need to be disabled

## 2.8.2 Integration to Cyber Security Management System

Each product configuration shall be backed up and the backups are to be stored in a safe place.

To ensure optimal performance, please verify on a regular basis if newer software is available for the products.

### 2.8.2.1 Incident Recovery Plan

The following tasks should be considered to be included in the overall owner's cyber security management system.

Task	Action
Local Independent Control	None.
Network Isolation	Unplug all RJ45 Ethernet cables from the back of all Marine Watch S panels. Note that this action will result in loss of communication alarms.
Extract Security Log	<p>Insert a USB flash drive on the Marine Watch S panel. From the Maintenance section of the Administrative menu, copy the Security Log to the USB flash drive.</p> <p>Repeat for all Marine Watch S panels. Make sure the file names are unique.</p>
Deterministic Outputs	None. The panels maintain all outputs in a fixed state, should an incident occur.
Backup & Restore	See below for details.
Controlled Shutdown, Reset, Roll-back and Restart	<p>It is safe to cut the power to the panels at any time. No Controlled Shutdown method is needed.</p> <p>See the recovery from backup section below on how to reset and roll-back.</p>

### 2.8.2.2 Backup and Recovery of System

	S-ONE	S-ACE
Backup	Take note of the software version	Take note of the software version
	Extract the configuration file to a USB-memory and store it	Take note of the following from the Administrative configurations <ul style="list-style-type: none"> <li>- IP Address</li> <li>- Panel Buzzer</li> <li>- Alarm Groups</li> <li>- Main Panel IP address</li> <li>- Panel Location</li> <li>- Buzzer when Attended Engine Room</li> </ul>
Recovery	Remove Ethernet cable(s)	Remove Ethernet cable
	Perform a software update to the version in the backup	Perform a software update to the version in the backup
	Perform factory reset	Perform factory reset
	Change PIN code	Change PIN code

	S-ONE	S-ACE
	Restore the backed-up configuration by loading the configuration from USB	Restore configuration manually
	Insert Ethernet cable(s)	Insert Ethernet cable

### 2.8.2.3 Periodical Functionality Audit

For S-ONE and S-ACE, at a minimum, perform the following periodically to verify security functionality.

1. Attempt to log in to the Administrative menu with an incorrect PIN.
2. Login to the Administrative menu with the correct PIN.
3. Insert a USB memory stick, and extract the security log from the Maintenance section of the Administrative menu.
4. On a PC, verify the two latest records are “admin unsuccessful log in” and “admin log in” in the ‘security\_log.csv’ file on USB.

## 3 The S-ONE User Interface

### 3.1 Header Information



The header consists of the following information.

- The logotype, if any. This can be changed in the configuration.
- The default panel name is **Marine Watch**. The name can be changed in the configuration.
- A common warning/alarm banner; flashing for new unacknowledged events.
- When the buzzer is active, the buzzer symbol is indicated in the centre of the banner.
- The two most recent unacknowledged events, if any, are displayed next to the event indicator.
- Various status symbols.
- The Time can be displayed as an option.

#### 3.1.1 Header Status Symbols

These symbols may appear in the header bar.

At least one channel indicates Alarm	At least one channel indicates Warning	At least one Alarm and at least one Warning
At least one alarm, one warning and one disabled channel	One or more channels are disabled by the operator	At least one new Alarm or Warning <sup>11</sup>
Watch responsible	The buzzer is sounding	

<sup>11</sup> The red alarm banner takes precedence over the yellow warning banner

## 3.2 The Home Page

The Home Page provides an overview of all the configured pages. By selecting a page, you can quickly access that page.

Any active event on a page is indicated with the corresponding warning- or alarm triangle symbol and a counter. Also, any disabled channels are indicated with a grey triangle.

The main menu can be accessed by selecting the ☰ symbol.



### 3.2.1 History Widget

The history widget displays the alarm status for the last 24 hours. Recurring alarms are indicated with a count. Select a time interval to see more detailed information.

### 3.2.2 Rudder Angle Indicators

The Marine Watch S provides one or two rudder angle indicators. If enabled, they are displayed on the Home Page. The presentation of the indicators depends on the configuration of the physical orientation of the panel itself.

### 3.2.3 Conditions

Any conditions which are configured for home page view, are displayed here.

## 3.3 The Alarm List

The Alarm List displays all events in a grid or list view. The Alarm List displays a green all OK symbol if no events are present. In case of the worst event is a warning, the background is coloured with warning colours.



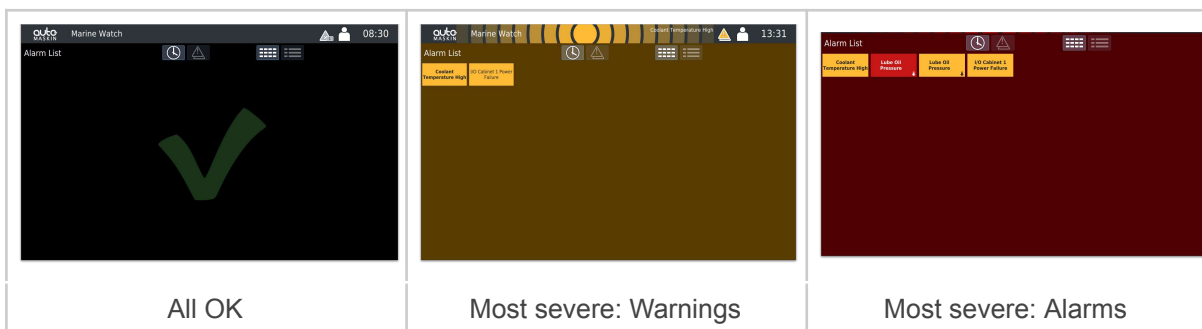

Likewise, if the worst event is an alarm, the background is coloured with alarm colours.

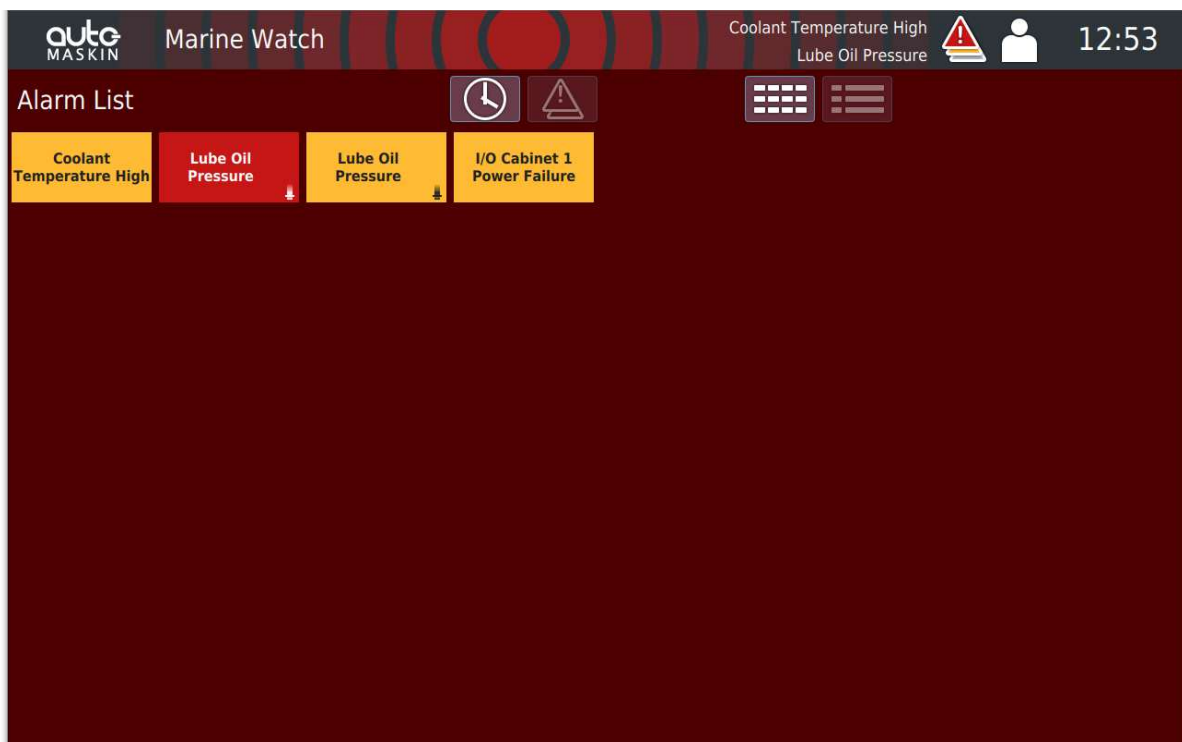

The events can be acknowledged from the panel if allowed in the configuration.



### 3.3.1 Symbols in the Alarm List

Symbols in the Alarm List	
	The events are sorted chronologically, with the most recent event first.
	The events are sorted by severity, with the most severe event category first.
	The events are displayed in a grid view.
	The events are displayed in a list view.

### 3.3.2 Alarm List Colour Coding

Alarm List Colour Coding		
<b>Warning text</b>	Bold black text on a yellow background	Active, unacknowledged warning
Warning text	Normal black text on a yellow background	Active, acknowledged warning
<b>Warning text</b>	Bold yellow text on a grey background	Inactive, unacknowledged warning
<b>Alarm text</b>	Bold white text on a red background	Active, unacknowledged alarm
Alarm text	Normal white text on a red background	Active, acknowledged alarm
<b>Alarm text</b>	Bold red text on a grey background	Inactive, unacknowledged alarm

### 3.3.3 Internal Events

The following internal events can be generated by the Marine Watch S system.

General System Status		
Main Panel Low Voltage	Warning	Main Panel voltage below 21 V for 30 seconds.
Dead Man Alarm	Alarm	The dead man alarm timer has expired.

Engineers Alarm <sup>12</sup>	Alarm	An event has not been acknowledged within the configured time.
Lost Contact to <location name> Panel	Warning	Communication is lost to any Subpanel or Annunciator Panel configured in the Marine Watch system.
Main Panel Communication Failure <sup>13</sup>	Warning	Communication with the Main Panel is lost.
Main Panel Incompatible	Warning	The Subpanel is not compatible with the Main Panel. Update software to latest available.
Abnormal Network State <sup>14</sup>	Warning	The panel has detected an abnormal network state.
<b>I/O Cabinet System Status</b>		
I/O Cabinet Communication Failure	Alarm	Communication with the I/O Cabinet is lost.
Diagnostic Failure	Warning	I/O data bus failure.
UPS Failure	Warning	UPS battery failure.
Power Failure	Warning	Power is below the limit – 12V system: 9.6V – 24V system: 19.2V
Circuit Breaker Tripped	Warning	The I/O Cabinet circuit breaker tripped.
<b>Engine Cabinet Status</b>		
Engine Communication Failure	Alarm	Communication with the engine interface is lost.
Engine CAN Bus Off	Alarm	The engine interface is in a CAN bus off state. Serious event and requires a power cycle of the engine cabinet. <sup>15</sup>

<sup>12</sup> Only for Periodically Unattended Engine Room configurations.

<sup>13</sup> Only for Subpanels.

<sup>14</sup> Verify network integration and network zone boundaries.

<sup>15</sup> If the condition re-occurs, check for potential short-circuit on the J1939 wiring.

### 3.4 The Channel Pages

For all channel pages, the displayed channel position is directly mapped to the connection in the I/O Cabinet.

For example, wiring a certain switch channel to the I/O Cabinet input will directly translate to a fixed position on the screen. This means that the channel pages can be compressed or spread depending on how the channels are wired.

#### 3.4.1 The Switch Channel Page

There will be one or several pages with rectangles. This is dependent on the configuration, the number of connected I/O Cabinets, and the type of I/O in each Cabinet.

Each rectangle represents the status of one switch input channel, and each page can display status from up to 60 channels.

Group 1		Group 2		Group 3		Group 4	
Switch Channel 1	Switch Channel 2	Switch Channel 3	Switch Channel 4	Switch Channel 5	Switch Channel 6	Switch Channel 7	Switch Channel 8
Swiirre 9 english	Switch Channel 10	Switch Channel 11	Switch Channel 12	Switch Channel 13	Switch Channel 14	Switch Channel 15	Switch Channel 16
Switch Channel 17	Switch Channel 18	Switch Channel 19	Switch Channel 20	Switch Channel 21	Switch Channel 22	Switch Channel 23	Switch Channel 24
Switch Channel 25	Switch Channel 26	Switch Channel 27	Switch Channel 28	Switch Channel 29	Switch Channel 30	Switch Channel 31	Switch Channel 32
Switch Channel 33	Switch Channel 34	Switch Channel 35	Switch Channel 36	Switch Channel 37	Switch Channel 38	Switch Channel 39	Switch Channel 40
Switch Channel 41	Switch Channel 42	Switch Channel 43	Switch Channel 44	Switch Channel 45	Switch Channel 46	Switch Channel 47	Switch Channel 48
Switch Channel 49	Switch Channel 50	Switch Channel 51	Switch Channel 52	Switch Channel 53	Switch Channel 54	Switch Channel 55	Switch Channel 56
Switch Channel 57	Switch Channel 58	Switch Channel 59	Switch Channel 60				

Channels can optionally be assigned to one of four different groups, and the group can be given a name and assigned a group colour.





Different alarm panels can be configured to indicate and allow acknowledgement for select groups of channels only.

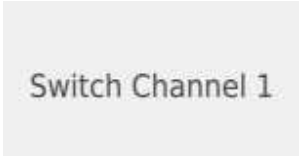

Note that channel OK can be indicated as a green or white rectangle, which can be changed in the menu.

### 3.4.1.1 Channel Status

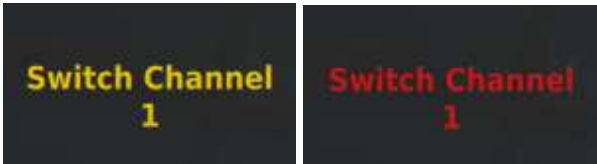
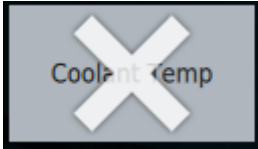
Each rectangle represents the status of a binary channel as follows.

Status	Description	Sample Graphic Representation
Normal	The channel is not alarming.	
Active and not acknowledged	The channel is alarming, following its persistence timer. Text in bold, flashing.	
Active and acknowledged	The channel is acknowledged by an operator and will clear when the alarm clears. Regular text.	
Inactive and not acknowledged	The channel has been activated but is not active now. It will clear when acknowledged. Grey background, bold flashing text in yellow/red.	
Disabled	An operator has disabled the channel. The rectangle is reduced in size and grey.	
Disabled, but active event	An operator has disabled the channel. Border in severity colour if the channel is active.	

### 3.4.2 The Analog Channel Page

The analog page can display up to eight channels in a 4 x 2 grid. Each channel is represented as a circular gauge or as a bar graph widget. An optional sparkline and trend indicator can be displayed.

A maximum of two analog pages can be displayed, holding a maximum of 16 analog channels.

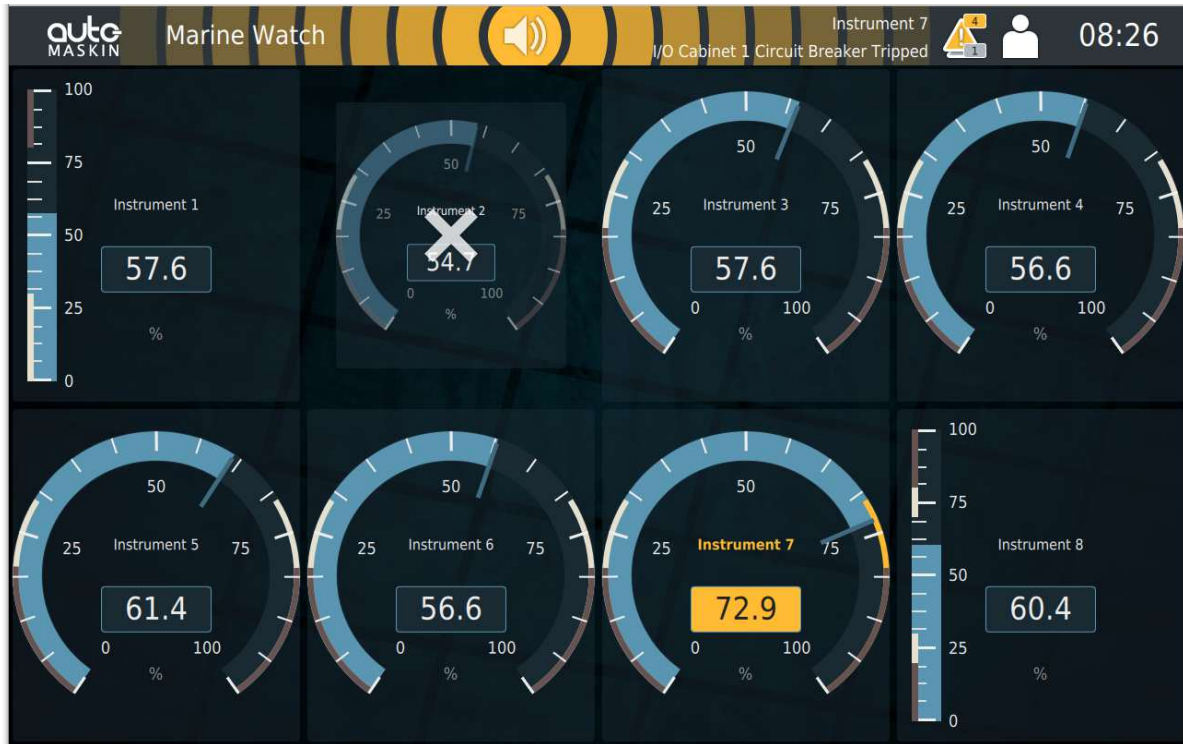



Analog channels are an option. If the I/O Cabinet does not include the analog option, then these pages are not displayed.

#### Widget Properties

Name	The analog signal description.
Value	Real-time value scaled between the sensor Min-Max value in the configuration. An out-of-limit value is indicated with "---".
Unit	The signal unit.
Min/Max Range	Instrument Min/Max values.
Alarm Limits	LoLo • Lo • Hi • HiHi
Sparkline	Optional sparkline for up to 1 hour of operation.

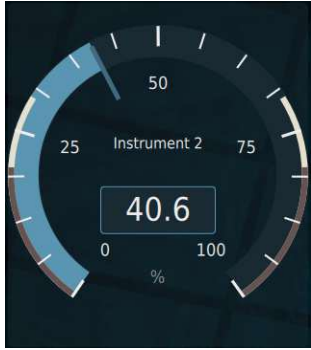
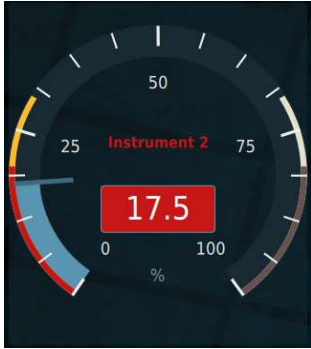
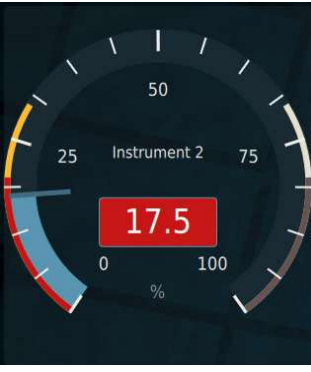
### 3.5.1 Channel Status

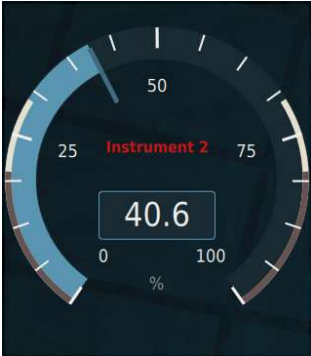
Status	Description	Sample Graphic Representation
Normal	The channel is not alarming.	
Active and not acknowledged	The channel is alarming, following its persistence timer. Instrument text in bold, flashing.	
Active and acknowledged	The channel is acknowledged by an operator and will clear when the alarm clears. Regular instrument text.	

Status	Description	Sample Graphic Representation
Inactive and not acknowledged	The channel has been activated but is not active now.  It will clear when acknowledged.	
Disabled	An operator has disabled the channel.	
Disabled but active event	An operator has disabled the channel, which indicates an event.	

### 3.4.3 The Output Channel Page

The panel can be configured to display up to 16 operator switches on one page.



Output channels are an option. If the I/O Cabinet does not include any expansion output channel modules, then these pages are not displayed.

The output channel page displays user-controlled output channels only. These output channels can be configured to be toggled or momentary. Only the Main Panel can control the outputs.

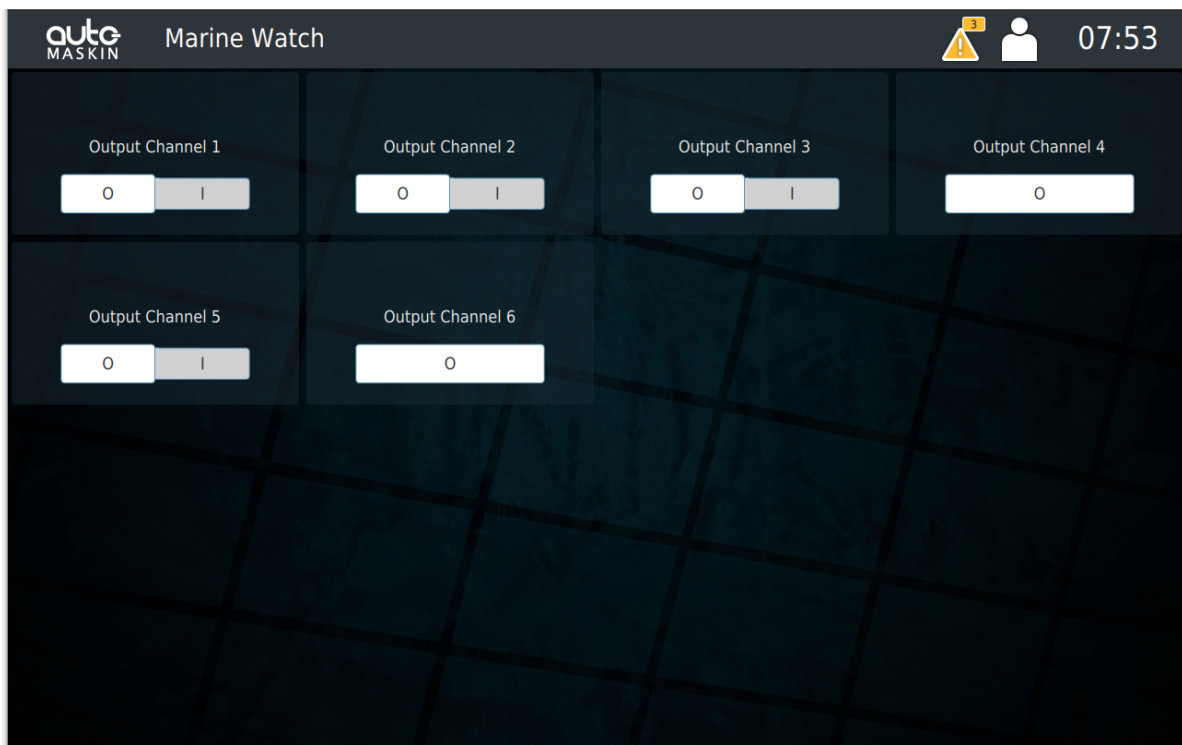

### 3.4.4 The Engine Channel Page

The panel can be configured to display

- Up to 2 propulsion engines
- Up to 2 genset engines



Displaying engine channels is an option and requires either Engine Cabinets or an existing Marine Pro system in order to interface the engine.

The page will adapt depending on the number of engines configured.



### 3.4.4.1 List of SPNs

The following SPNs are shown in the page.

Propulsion		Genset	
SPN	Name	SPN	Name
190	Engine RPM	247	Engine Hours
92	Engine Load Percentage	100	Engine Oil Pressure
247	Engine Hours	110	Engine Coolant Temperature
100	Engine Oil Pressure	2440	Generator AC Voltage
110	Engine Coolant Temperature	2448	Generator Amps
102	Boost Pressure	190	Generator Cycles

Propulsion		Genset	
SPN	Name	SPN	Name
94	Fuel Pressure	3590	Percent of Load
127	Gear Oil Pressure	168	Battery Voltage
177	Gear Oil Temperature		
168	Battery Voltage		
52	Aftercooler Temperature		
95	Fuel Pressure Diff		

### 3.5 Screen Navigation

This is how to operate and navigate the panel.

Action	Do this
Acknowledge an event	<p>Tap the event in the Alarm List.</p> <p>Tap the event widget. The event widget is</p> <ul style="list-style-type: none"> <li>the rectangle – for binary/switch channels</li> <li>the circular gauge or bar graph – for analog channels</li> </ul>
Disable Channel	Push and hold the corresponding widget for one second to disable the channel until enabled or for a given time.
Next Screen	Swipe left on the screen.
Previous Screen	Swipe right on the screen.

## 4 The S-ONE Main Menu

The Main Menu is always available to the operator. It is divided into several sections as follows.

### 4.1 Attendance

The Attendance menu is available only if any of the following has been configured.

- Periodically Unattended Engine Room (enables the Engine Room section)
- Location is engine room or engine control room (enables the Dead Man Alarm and the Engineers Call section)

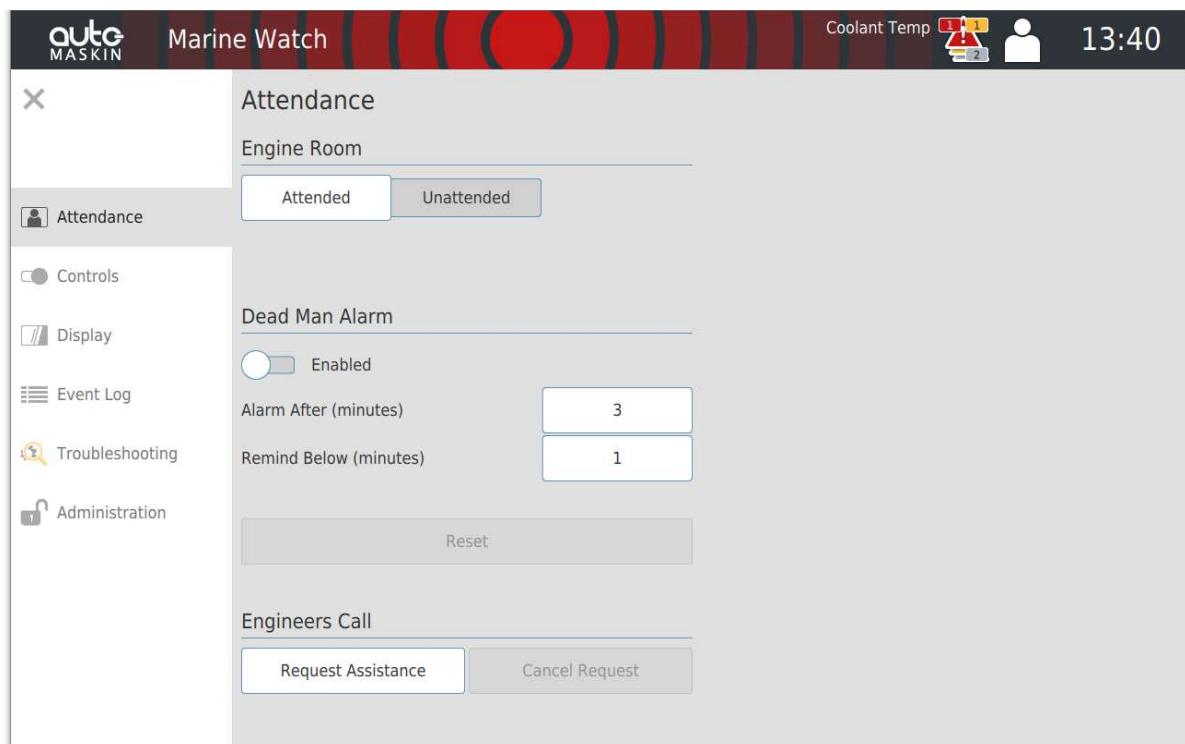

#### 4.1.1 Engine Room

Select **Attended** or **Unattended** to perform a watch transfer. See the chapter [Periodically Unattended Engine Room](#) for further information.

### 4.1.2 Dead Man Alarm

This function can sound the alarm if the engineer has not reset the timer in time. A notification dialogue is indicated on the Engine Room and Engine Control Room panels before the alarm sounds. The alarm, however, is broadcasted to all panels.

A panel I/O output can be configured to indicate a dead man reminder, and a panel I/O input can reset the alarm timer.

### 4.1.3 Engineers Call

The engine or control room engineer can request assistance from any other panel in the Marine Watch S system. The request can be directed to a specific panel or broadcast to all.

## 4.2 Controls

These settings are possibly used frequently.

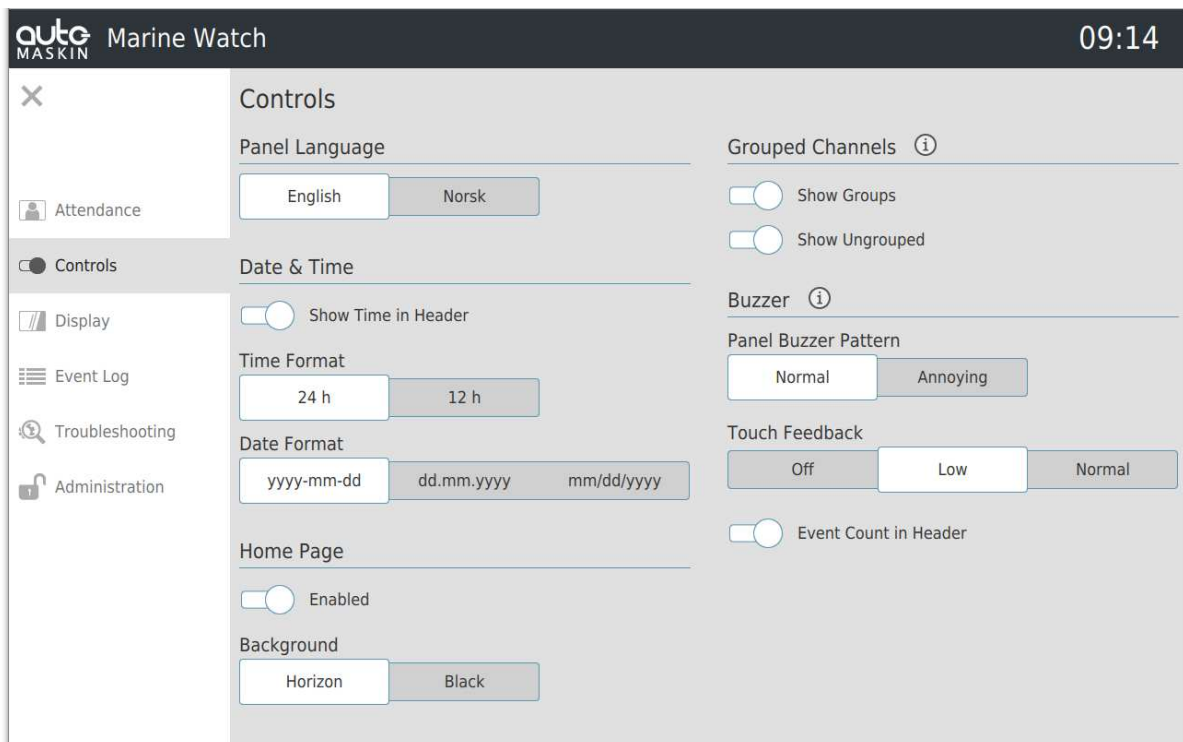

### 4.2.1 Panel Language

Select the preferred panel language.

#### 4.2.2 Date & Time

Date and time formatting can be selected, with the option of displaying the time in the header.

#### 4.2.3 Home Page

The Home Page is a default but optional overview of all the pages, which makes it easy to navigate to any page.

#### 4.2.4 Grouped Channels

A channel assigned to a group can be indicated with a coloured rectangle and an optional group name. It is possible to assign each channel to one of four different groups.



By default, a channel does not belong to any group.

#### 4.2.5 Buzzer

The panel buzzer volume can be configured in the administrative part of the menu.

Panel Buzzer Pattern	
Standard	Standard on / off pattern.
Annoying	Four quick beeps.
Touch Feedback	
Off	Silenced.
Low	50 % volume.
Normal	100 % volume.

#### 4.2.5.1 Event Count in Header

The event count per severity can be configured to be displayed in the header. Also, any disabled channels are indicated.



### 4.3 Display

Various display settings are controlled from here.

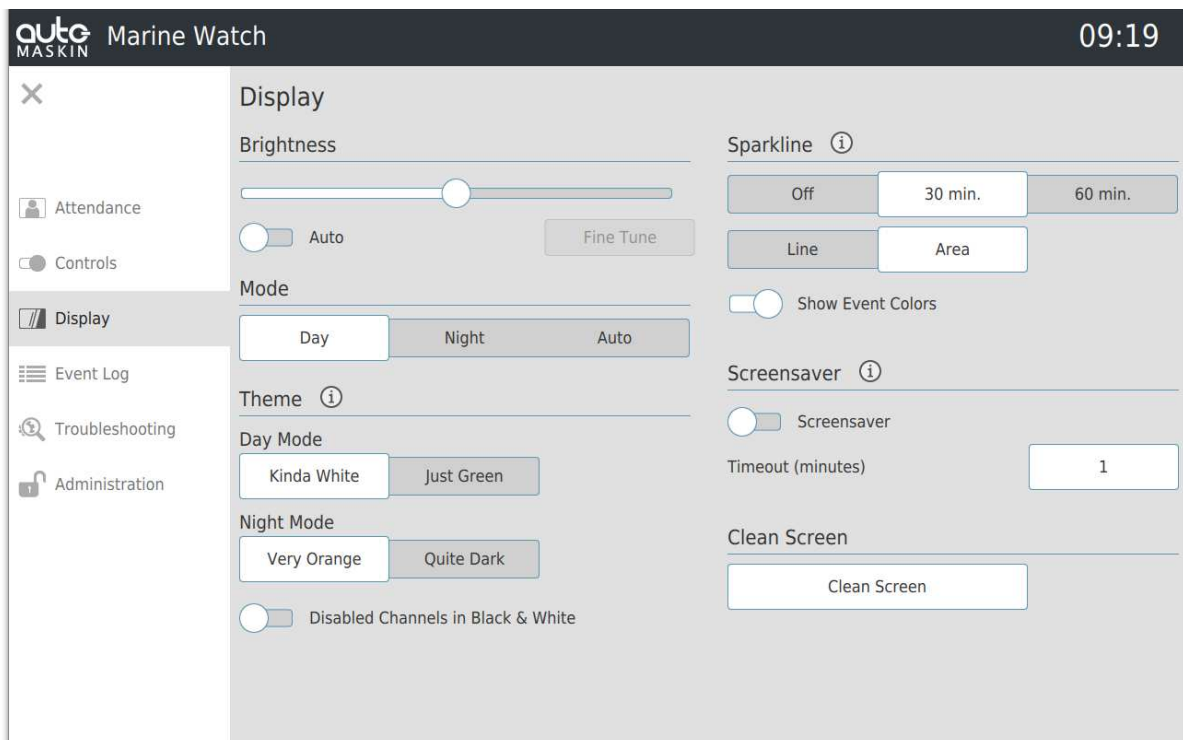

#### 4.3.1 Brightness

Brightness	
Brightness slider	Manually adjust the backlight brightness (0-100%).
Auto	The backlight brightness is adjusted automatically. <b>Note!</b> Using the physical buttons to change the brightness will set Auto to Off.

### 4.3.2 Mode

Mode	
Day	Colours optimised for daylight.
Night	Colours are optimised for use in dark environments.
Auto	Switch automatically between Day and Night modes.

### 4.3.3 Theme

Theme	
Day Mode	Choose a colour representation for use in Day mode
Night Mode	Choose a colour representation for use in Night mode

Disabled channels can be configured to be displayed in black & white.

### 4.3.4 Sparkline

A Sparkline is a miniature chart contained within the circular gauge and bar graph. Choose between 30 or 60 minutes of history, line or area representation, and whether the sparkline shall indicate channel threshold colours.

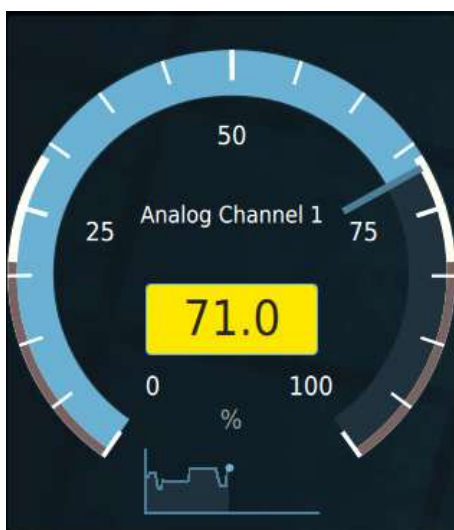

### 4.3.5 Screensaver

Screensaver	
Screensaver	Enables the screensaver. The screensaver will activate when there are no events.
Timeout (minutes)	Set the inactivity time in the number of minutes until the screensaver activates. Any active or new event will deactivate the screensaver.

### 4.3.6 Clean Screen

Clean Screen	
Clean Screen	Displays the screen in all black so fingerprints are clearly visible and can be wiped off with a clean soft cloth. Press the button on the screen to exit.

## 4.4 Event Log

The event log is displayed in chronological order.

The screenshot shows the 'Event Log' window in the Marine Watch application. The interface includes a sidebar with navigation options: Attendance, Controls, Display, Event Log (selected), Troubleshooting, and Administration. The main area displays a table of events with the following columns: Type, Description, and Timestamp. The events are listed in chronological order from top to bottom.





Type	Description	Timestamp
	I/O Cabinet 1 Switch Channel 2 Coolant Temp Alarm - Acknowledged	13:45:24 2023-11-24
	I/O Cabinet 1 Switch Channel 2 Coolant Temp Enabled by operator	13:40:10 2023-11-24
	Marine Watch Header event config: Event Count	13:40:04 2023-11-24
	I/O Cabinet 1 Switch Channel 4 Coolant Temperature High Disabled by operator	13:31:58 2023-11-24
	Marine Watch I/O Cabinet 1 Power Failure Warning - Acknowledged	13:31:08 2023-11-24
	I/O Cabinet 1 Analog Channel 1 Lube Oil Pressure Disabled by operator	13:30:31 2023-11-24
	I/O Cabinet 1 Analog Channel 1 Lube Oil Pressure LoLo - Acknowledged	13:30:09 2023-11-24
	I/O Cabinet 1 Switch Channel 4 Coolant Temperature High Enabled by operator	12:42:22 2023-11-24
	I/O Cabinet 1 Analog Channel 1 Lube Oil Pressure LoLo - Active	12:42:07 2023-11-24
	I/O Cabinet 1 Analog Channel 1 Lube Oil Pressure Lo - Active	12:42:07 2023-11-24

The Event Log holds the last 1000 events and can be exported to a USB storage device as a CSV file.

It is possible to filter the Event Log further by pressing and holding the event Type, or the event symbol, e.g. the warning triangle.



If the Event Log is filtered, a “Show All” button will appear at the top, making it possible to reset the filtering.

Legend		
Indication		An Alarm event.
		A Warning event.
		Configuration change.
		Information.

## 4.5 Troubleshooting

The Troubleshooting menu can be used to help diagnose faults.

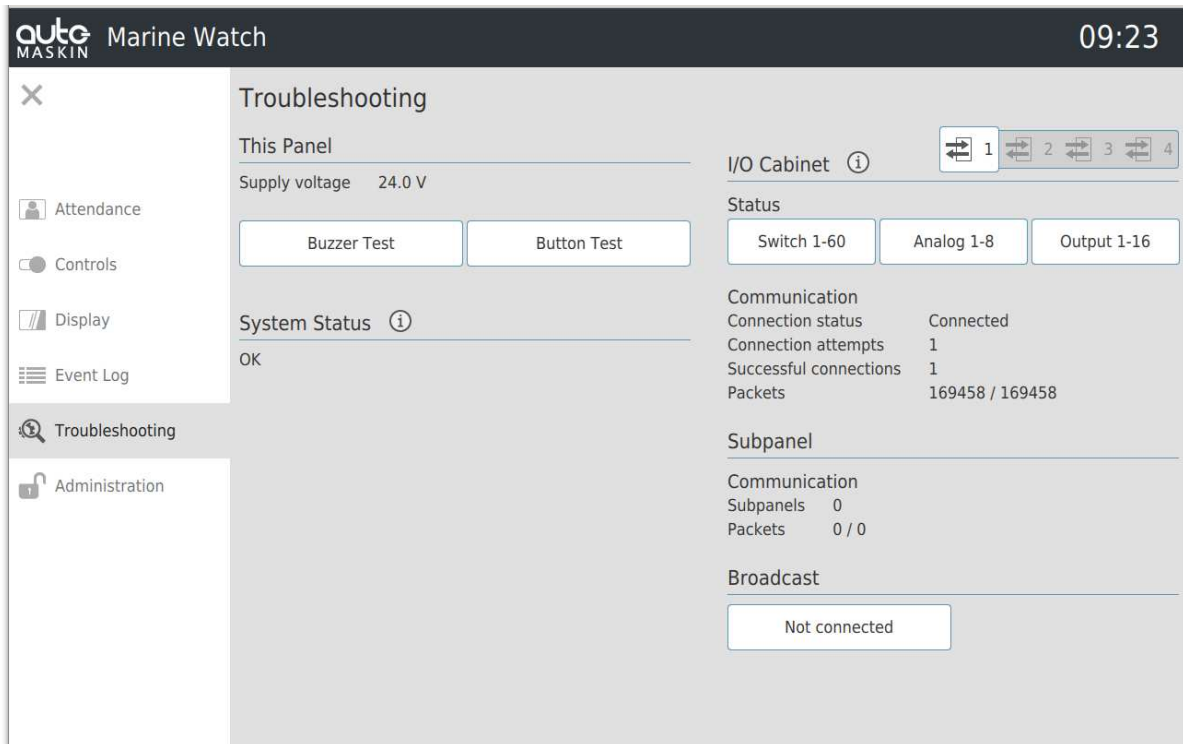

### 4.5.1 This Panel

Troubleshooting this panel.

Indication	
Supply Voltage	The panel supply voltage is displayed.
Buttons	
Buzzer Test	Press and hold the button to activate the buzzer.
Button Test	The button brings up a dialogue for testing the panel's physical buttons.
Diagnostics	The button brings up a dialogue showing various internal information.

### 4.5.2 System Status

The active internal events, if any, are listed here.

Unacknowledged events are listed in bold. Press the corresponding Acknowledge button to acknowledge the event.

See the chapter [Internal Events](#) for a definition of all internal events.

### 4.5.3 I/O Cabinet

Troubleshooting of the selected I/O Cabinet.

<b>Status</b>	
Switch 1-60 <sup>16</sup>	See the status of the binary channel at the I/O Cabinet.
Analog 1-8 <sup>17</sup>	See the status of the analog channel at the I/O Cabinet.
Output 1-8 <sup>18</sup>	See the status of the output channels at the I/O Cabinet.
<b>Communication</b>	
Connection state	Connectivity status between the Main Panel and the I/O Cabinet.
Connection attempts	Connection attempts since the last restart of this panel.
Successful connections	Number of successful connections since the last restart.
Packets	Data packets transmitted / received.

### 4.5.4 Conditions

If any conditions are configured, the status of the condition can be inspected here.

### 4.5.5 Subpanel

Troubleshooting of any connected Subpanel.

<b>Communication</b>	
Subpanels	Number of connected Subpanels
Packets	Data packets transmitted / received

<sup>16</sup> Additional buttons may be displayed depending on the I/O Cabinet capacity.

<sup>17</sup> Displayed only if supported by the I/O Cabinet.

<sup>18</sup> Displayed only if supported by the I/O Cabinet.

### 4.5.6 Marine Broadcast

If the Marine Broadcast functionality is enabled, connection status to the cloud server is indicated here.

## 4.6 Administration

This is the login page for the Administration menu. It also displays some data as follows.

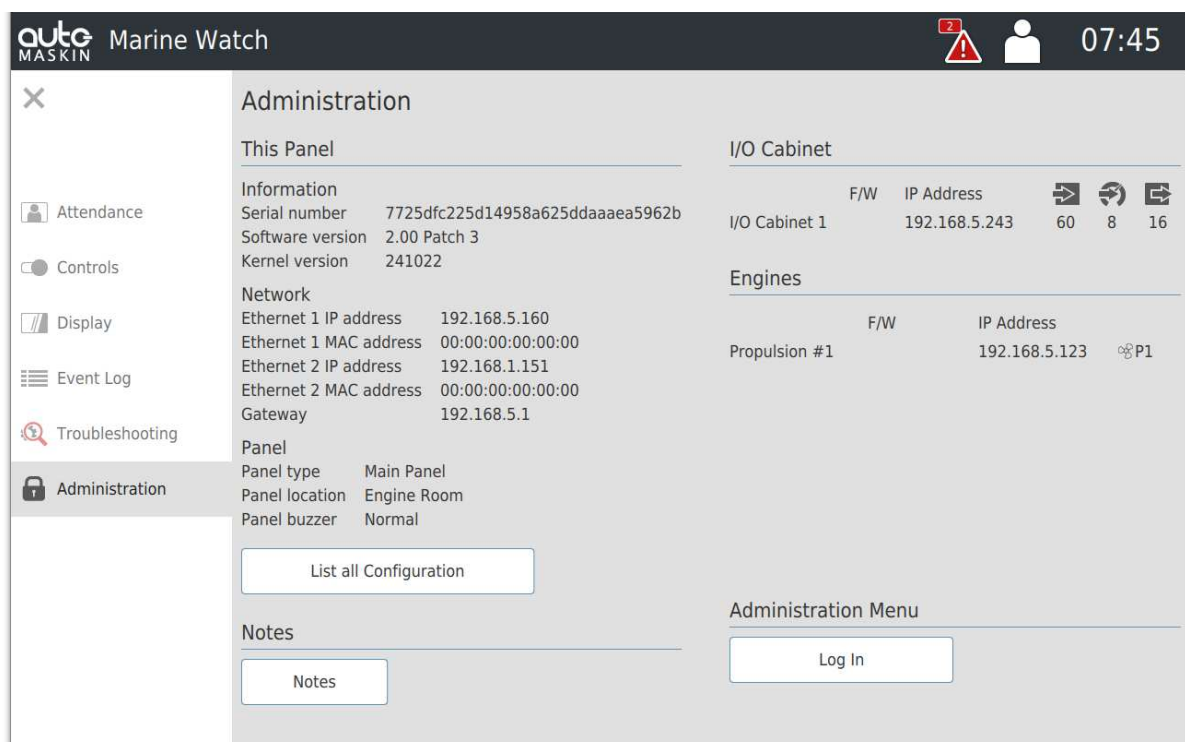

### 4.6.1 This Panel

This section highlights the panel configuration.

All configuration can be inspected and saved to an USB memory stick by pressing the **List all Configuration** button.

### 4.6.2 Notes

If the panel contains any notes, they are displayed here. Panel notes are configured in the administrative pages. All panel operators can read notes.



If no notes are configured, then the Notes section is not displayed.

### 4.6.3 I/O Cabinet

This section lists the I/O Cabinets in use. Each I/O Cabinet lists the IP address and the I/O Cabinet capacity.

### 4.6.4 Engines

This section lists the Engines in use. Each engine lists the type of engine as well as its IP address.

### 4.6.5 Administration Menu

This login button is the entrance to the Administration Menu.

Press the **Log In** button to log in, then add the following info into the dialogue.

- User: **admin**
- PIN code: **1234**

The screenshot shows a dialog box titled "Administration Log In". It features a close button (X) in the top-left corner. Below the title bar, there are two input fields. The first field contains the text "admin". The second field is labeled "PIN code" and contains the text "PIN code". To the right of the PIN code field is an eye icon. At the bottom of the dialog, there are two buttons: "Cancel" and "Log In".



Three failed PIN code attempts will result in a PIN code lockout for 5 minutes, and also an encrypted PIN code.

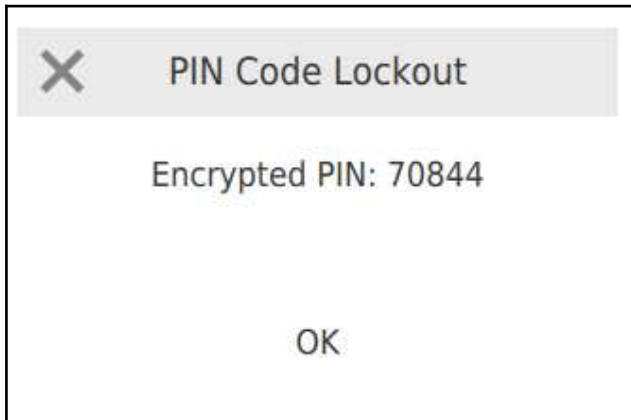

If the PIN Code is lost, then your distributor can source the PIN code using the encrypted PIN code.

The following buttons can appear.

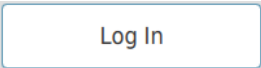
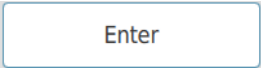
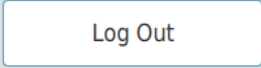
Buttons	
	Press the <b>Log In</b> button to access the login dialogue.
	Already logged in. Press the <b>Enter</b> button to access the Administration menu.
	<b>Log Out</b> the active user to remove access to the Administration menu.

## 5 The S-ONE Administration Menu

All the configuration is performed in the varying sub-sections of the Administration Menu. Any configuration change is saved in the Alarm Panel as soon as it is entered.

### 5.1 This Panel

This section holds the top-level configuration of this panel.



The page is scrollable. Scroll down to see all configurations of This Panel.

The screenshot shows the 'This Panel' configuration page. The left navigation menu includes: Administration, This Panel (selected), System, Switch Channels, Analog Channels, Engine Channels, Output Channels, Group Channels, Conditions, Maintenance, and Return. The main content area is divided into several sections:

- Panel Name:** A text input field containing 'Marine Watch'.
- Panel Type:** Two buttons: 'Main Panel' (selected) and 'Subpanel'.
- Panel Location:** A dropdown menu showing 'Engine Room'.
- Panel Buzzer:** Three buttons: 'Off', 'Low', and 'Normal' (selected).
- Panel Orientation:** Two buttons: 'Forward' (selected) and 'Aft'.
- Panel I/O:** A section with an information icon.
- Network:** Three text input fields: 'Ethernet 1 IP address' (192.168.5.160), 'Ethernet 2 IP address' (192.168.1.151), and 'Gateway' (192.168.5.1).
- Disable & Acknowledge:** A section with an information icon containing:
  - Channel Disable:** Two buttons: 'Allowed' (selected) and 'Disallowed'.
  - Allow Acknowledge:** Four toggle switches: 'Ungrouped' (off), 'Group 1' (off), 'Group 2' (off), 'Group 3' (off), and 'Group 4' (off).
  - Press and Hold of the Acknowledge Button:** Three buttons: 'Nothing' (selected), 'Ack. Page', and 'Ack. All'.

#### 5.1.1 Panel Name

The Panel Name is displayed in the header bar, just after the logo displayed top-left.

#### 5.1.2 Panel Type

Choose between **Main Panel** and **Subpanel**.

If this is the only Alarm Panel in the network, then it shall be a Main Panel. Other panels in the network shall be of type Subpanel.



There shall be only one Main Panel in a network. Having multiple Main Panels connected to the same I/O Cabinet can cause unpredictable behaviour.

### 5.1.3 Panel Location

Select a location for this panel. The panel location is used for the following functions

- Watch Transfer (see chapter [Periodically Unattended Engine Room](#) for more information)
- Dead Man Alarm and Engineers Call (functions are enabled for the engine room and engine control room)

The panel location can be selected to any of the following.

Panel Location	
Engine room	The panel is located in the engine room.
Engine control room	The panel is located in the engine control room.
Bridge	The panel is located on the bridge.
Engineers cabin	The panel is located in an engineers cabin.
Other / Public spaces	The panel is located in any other location.

#### 5.1.3.1 Buzzer when Attended Engine Room

If the **Bridge** panel location is selected, and **Periodically Unattended Engine Room** is enabled, the panel can be configured for which groups the buzzer shall be enabled for new events.

### 5.1.4 Panel Buzzer

Select the panel buzzer volume for new events.

Panel Buzzer	
Off	Silenced.
Low	50 % volume.

Panel Buzzer	
Normal	100 % volume.



It is possible to connect an external buzzer to the I/O Cabinet or to the panel I/O itself.

This is required to fulfil sound requirements in a type-approved installation.

### 5.1.5 Panel Orientation

Sets the physical orientation of the panel. This configuration only affects the graphical visualisation of the rudder angle indicators on the Home Page.

#### Forward

The panel is facing the front of the vessel.



#### Aft

The panel is facing the stern of the vessel.



### 5.1.6 Network

Set the IP address of this Alarm Panel. The default IP address of Ethernet 1 is 192.168.0.151. Ethernet 1 is the preferred port for network communication.



The IP addresses of the S-ONE Alarm Panel can not be configured to the same subnet. For instance, Ethernet 1 set to 192.168.0.151 and Ethernet 2 set to 192.168.0.161 is not allowed.

Make sure that all IP addresses in use on the network are unique.

The Gateway configuration is required if using the Marine Broadcast functionality. The Gateway shall then be set to the default gateway of the network.



Contact the network administrator if unsure about the gateway configuration.

## 5.1.7 Disable & Acknowledge

### 5.1.7.1 Channel Disable

Select if this panel shall have the possibility to disable and enable channels.

### 5.1.7.2 Allow Acknowledge

Select which channel group(s) this panel shall have the authority to acknowledge.

### 5.1.7.3 Press and Hold of the Acknowledge Button

Configures the behaviour of a long-press on the acknowledge button.

Acknowledge Button	
Nothing	No action.
Ack. Page	Acknowledge all events visible on this page.
Ack. All	Acknowledge all events.

## System-wide Buzzer Silence

Configures the behaviour of the buzzer in the entire system.



This configuration option is only present for Subpanels.

System-wide Buzzer Silence	
Enabled	Silences the buzzer on all panels in the system.
Disabled	Silences the buzzer locally on this panel only.

### 5.1.8 Panel I/O

First select Input or Output for the desired panel I/O. Then select the function to be used.

#	Type	Function
1	Input	Silence Buzzer
2	Input	Reset Dead Man Alarm
3	Input	None
4	Input	None
5	Input	Unacknowledged Events
6	Input	Buzzer Active
7	Input	None
8	Input	None

#### Input Functions<sup>19</sup>

Silence Buzzer	Silences the panel buzzer.
Reset Dead Man Alarm	Resets the Dead Man Alarm timer.

#### Output Functions

Buzzer Active	Active when the panel buzzer is active. Note that the panel buzzer can be disabled, but this does not affect this function.
Unacknowledged Events	Active for any unacknowledged events.
Active or Unacknowledged Events	Active for any active or unacknowledged events.

<sup>19</sup> All input functions are edge triggered, meaning they activate on a 0V to 24 V transition.

Output Functions	
Watch Responsible	Active when the panel is watch responsible.
Dead Man Alarm Reminder	Active when the dead man alarm timer is below the configured reminder time.

## 5.2 System

System configuration for the Marine Watch S system.

The screenshot displays the 'System' configuration page in the auto MASKIN Marine Watch software. The left sidebar contains navigation options: Administration, This Panel, System (selected), Switch Channels, Analog Channels, Engine Channels, Output Channels, Group Channels, Conditions, Maintenance, and Return. The main content area is titled 'System' and includes the following sections:

- I/O Cabinet:** A row of four cabinet icons labeled 1, 2, 3, and 4.
- Network:** A list of four I/O Cabinets with their respective IP addresses:
  - I/O Cabinet 1: 192.168.5.160
  - I/O Cabinet 2: 192.168.0.12
  - I/O Cabinet 3: 192.168.0.13
  - I/O Cabinet 4: 192.168.0.14
- Type:** A 'Detect' button.
- Switch Channels:** Input fields for 60 and 120.
- Analog Channels:** Input fields for 0, 8, and 16.
- Output Channels:** Input fields for 0, 8, 16, 24, and 32.
- Engines:** A section with an information icon.
- System Setup:**
  - Periodically Unattended Engine Room:
  - Engineers Alarm Timeout (minutes): 3
  - Broadcast:
  - Broadcast Server: broadcast.auto...
- Rudder Angle:**
  - PORT:  Port
  - STBD:  Starboard
- Panels in System:** An 'Add Offline Panel' button.

If the panel is configured as a Subpanel, the Main Panel IP address shall be configured, and not the I/O Cabinet IP address.



The screenshot shows the 'Main Panel' configuration section. Under the 'Network' heading, the 'IP address' field is set to 192.168.5 .93.

## 5.2.1 I/O Cabinet

### 5.2.1.1 Network

Set the IP address of the I/O Cabinet in the network. The default IP address for an I/O cabinet is 192.168.0.11.

The Marine Watch system currently supports connection with up to four I/O Cabinets. In each I/O Cabinet, locate the bus coupler and set the rotary switches S1 and S2 as follows:

I/O Cabinet	S1	S2	IP address
I/O Cabinet 1 (default)	1	1	192.168.0.11
I/O Cabinet 2	1	2	192.168.0.12
I/O Cabinet 3	1	3	192.168.0.13
I/O Cabinet 4	1	4	192.168.0.14



Make sure to reboot the I/O Cabinet after any changes to the S1 or S2 rotary switches.

### 5.2.1.2 Type

Select the correct I/O Cabinet type from the range of supported I/O Cabinets. This menu option is available only if the panel is configured to be the Main Panel.



Make sure the selected I/O Cabinet type is matching the actual I/O in the I/O Cabinet. Otherwise, unpredictable behaviour can occur.

It is possible to auto-detect the I/O Cabinet type by pressing the Detect button. If the detection is successful, a confirmation dialogue will appear before committing the I/O Cabinet type.

## 5.2.2 Engines

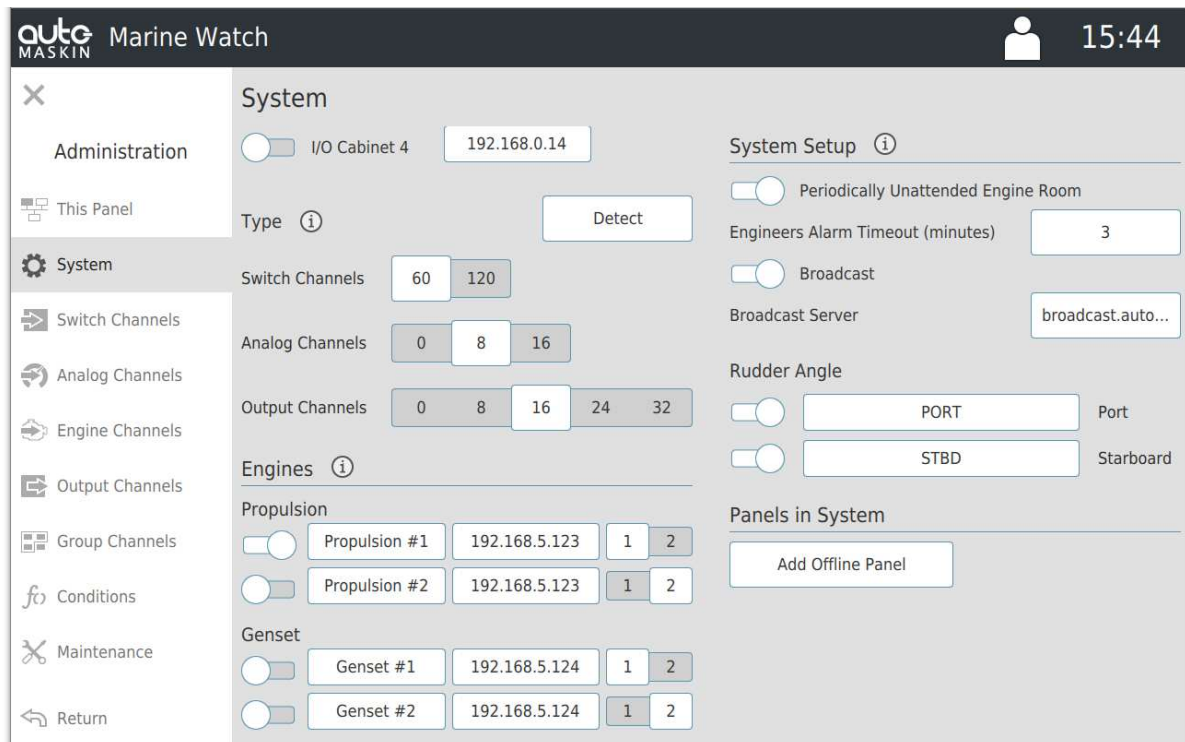

### 5.2.2.1 Propulsion / Genset

Enable / disable the desired engine interfaces that should be monitored. By enabling an engine, it shows up automatically on the engine page. The engine can be given a name. Select the J1939 interface on the Engine Cabinet.

## 5.2.3 System Setup

### 5.2.3.1 Periodically Unattended Engine Room

If the Marine Watch S system shall support periodically unattended engine room installations, this needs to be enabled. By enabling this option, the following functions are enabled

- Watch Responsible Indication
- Watch Transfer
- Engineers Alarm

See the chapter [Periodically Unattended Engine Room](#) for more information.

### 5.2.3.2 Engineers Alarm Timeout

Select the time before the Engineers Alarm will activate. The Engineers Alarm will activate if an event has not been acknowledged within the configured time in an unattended engine room situation.

### 5.2.3.3 Marine Broadcast

By enabling this configuration, the S-ONE will automatically transfer data to a secure cloud server, making the data accessible from any device. Enabling this feature will increase network data usage.



The S-ONE needs to have Internet access, and the Gateway configuration under This Panel must be correctly configured.

For more information on the Marine Broadcast, please see the Marine Broadcast User Manual.

### 5.2.3.4 Rudder Angle

Select and enable analog channels to be used as rudder angle indicators. When enabled, they are displayed on the Home Page of the panel.



If the system has two rudder angles, make sure the port and starboard rudder angles are correctly configured.

## 5.2.4 Panels in the System

Select the panels to be monitored in the Marine Watch S system. Selected panels can be named, and the system will issue warnings if the communication to the panel is lost.

If all panels are installed and configured correctly, the list will automatically populate, and the configurator only needs to select which panels to be included, typically all. In addition, there is a possibility to add off-line panels by IP address.

### 5.3 Switch Channels

All switch channels are configured here. To edit, the panel must be a Main Panel.

#	Channel Description	Condition	Type	Switch Type	Delay
1	Switch Channel 1	Engine Running	Warning	Alarm	1
2	Switch Channel 2	None	Warning	Alarm	1
3	Switch Channel 3	None	Warning	Alarm	1
4	Switch Channel 4	None	Warning	Alarm	1
5	Switch Channel 5	None	Warning	Alarm	1
6	Switch Channel 6	None	Warning	Alarm	1
7	Switch Channel 7	None	Warning	Alarm	1
8	Switch Channel 8	None	Warning	Alarm	1
9	Swiirre 9 english	None	Warning	Alarm	1
10	Switch Channel 10	None	Warning	Alarm	1
11	Switch Channel 11	None	Warning	Alarm	1
12	Switch Channel 12	None	Warning	Alarm	1

The configuration for each switch channel is as follows.

Type	
#	Press the channel number to enable or disable that channel.
Channel Description	The text displayed in the rectangle. Maximum 45 characters and four lines of text; word wrapping is performed automatically.
Condition	Select conditions which must be fulfilled in order for this channel to issue an event.
Type	Choose Warning or Alarm, depending on the required event type.
Switch Type	A Normally Open (NO) channel activates when the switch is closed. A Normally Closed (NC) channel activates when the switch opens. The latter is preferred.

Type	
Delay	Select a suitable persistence delay time in seconds before the event is triggered.

## 5.4 Analog Channels

All analog channels are configured here. To edit, the panel must be a Main Panel.

#	Sensor				Instrument							
	Type	Min	Max	Unit	Min	Max	LoLo	Lo	Hi	HiHi	Delay	
1	Analog Channel 1	0	100	%	No Condition	0	100	21	30	70	80	3
2	Analog Channel 2	0	100	%	No Condition	0	100	20	30	70	80	1
3	Analog Channel 3	0	100	%	No Condition	0	100	20	30	70	80	1
4	Analog Channel 4	0	100	%	No Condition	0	100	20	30	70	80	1
5	Analog Channel 5	0	100	%	No Condition	0	100	20	30	70	80	1
	Analog Channel 6				No Condition							

The configuration for each analog channel is as follows.

Type	
#	Press the channel number to enable or disable that channel.
Description	The text that is displayed in the circular gauge or bar graph. Maximum 45 characters and four lines of text; word wrapping is performed automatically.
Condition	Select conditions which must be fulfilled in order for this channel to issue an event.

Type	
Gauge Style	Visual configuration of the gauge, together with a preview.
Sensor Type	Select the sensor type connected to the I/O Cabinet.
Sensor Min	Analog sensor low range.
Sensor Max	Analog sensor high range.
Unit	Sensor unit, e.g. Bar, PSI, %, etc.
Instrument Min	Displayed low range.
Instrument Max	Displayed high range.
LoLo / Lo / Hi / HiHi	Warning/Alarm limits. <b>Note!</b> Leaving the field empty indicates no event.
Delay	Select a suitable persistence delay time in seconds before the event is triggered.



Make sure the connected analog sensors match the input channels in the I/O Cabinet. The input channels accept 4-20mA and 0-10V signals. The Sensor Min and Sensor Max configuration shall match the actual sensor min and max

### 5.4.1 Analog Channel Style

By pressing the Style button, a dialog is displayed where it is possible to preview the channel, as well as making graphical changes.

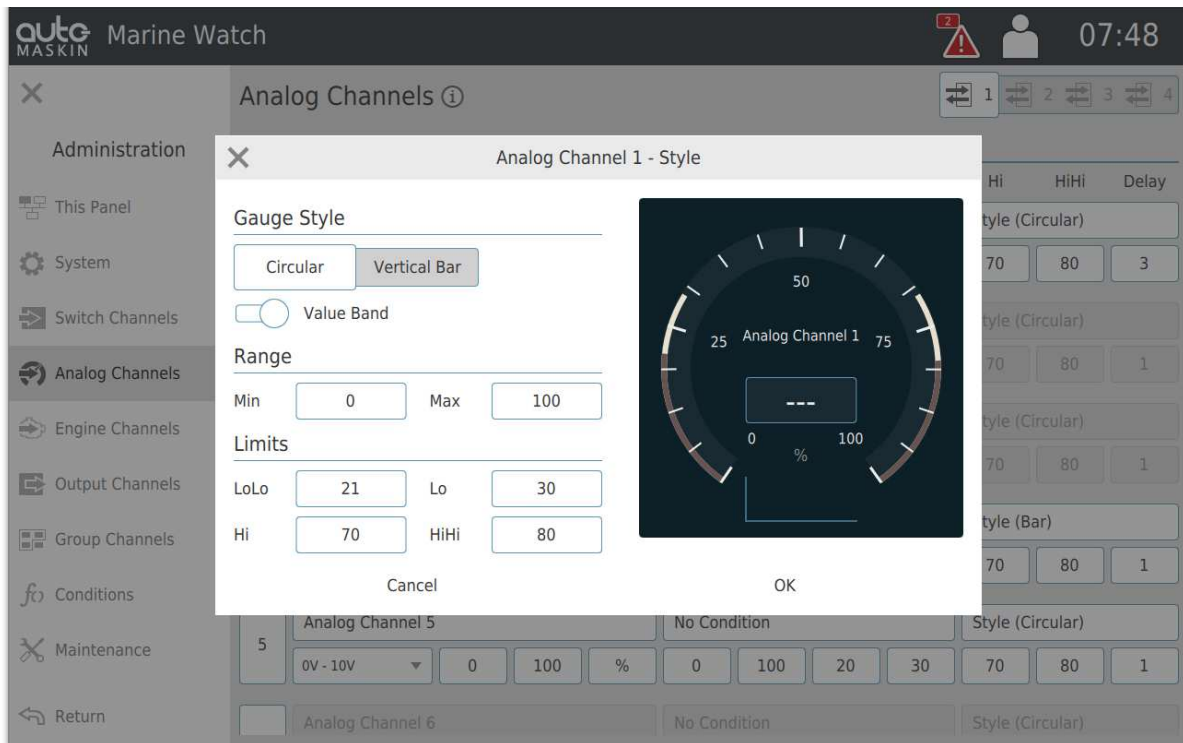

The configuration of each analog channel is as follows.

Type	
Circular / Vertical Bar	Select a circular gauge or a vertical bar graph.
Value Band	For circular gauge, select if the value band shall be shown or not.
Range	Displayed low range and high range.
Limits	Warning/Alarm limits. <b>Note!</b> Leaving the field empty indicates no event.

## 5.5 Engine Channels

All engine channels are configured here. To edit, the panel must be a Main Panel.

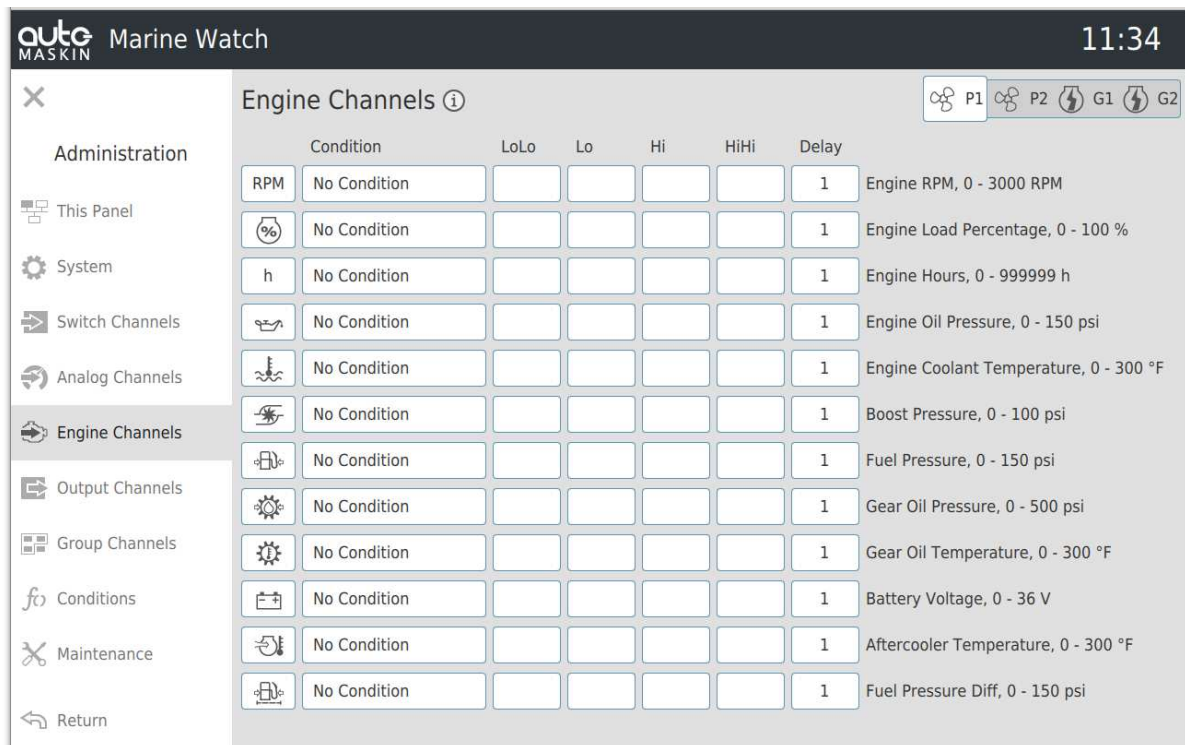

The configuration for each engine channel is as follows.

Type	
Icon symbol	Press the channel icon to enable or disable that channel.
Condition	Select conditions which must be fulfilled in order for this channel to issue an event.
LoLo / Lo / Hi / HiHi	Warning/Alarm limits. <b>Note!</b> Leaving the field empty indicates no event.
Delay	Select a suitable persistence delay time in seconds before the event is triggered.

## 5.6 Output Channels

The Standard Output Channels are always included in the Marine Watch I/O Cabinet.

The Expansion Output Channels are optional modules.

### 5.6.1 Standard Output Channels

Select the required function on the standard output module. The function for the first three standard output channels is locked.

The screenshot shows the 'Output Channels' configuration screen in the Marine Watch software. The interface has a dark header with the 'auto MASKIN' logo and 'Marine Watch' text. On the right of the header, there are status indicators: 'I/O Cabinet 1 Communication Failure' and 'Lost Contact to Bridge Panel' with a warning icon, and the time '10:29'. A navigation menu on the left includes 'Administration', 'This Panel', 'System', 'Switch Channels', 'Analog Channels', 'Output Channels' (highlighted), 'Group Channels', 'Conditions', 'Maintenance', and 'Return'. The main content area is titled 'Output Channels' and has two tabs: 'Standard' (selected) and 'Expansion'. Below the tabs is a table with 8 rows, each representing an output channel. The first three channels (1, 2, and 3) are greyed out, indicating they are locked. Channels 4 through 8 are active and have dropdown menus for function selection. Channel 4 is set to 'Buzzer Active', channel 5 to 'Unacknowledged Events in Group 1', and channels 6, 7, and 8 are set to 'None'. At the top right of the table area, there are four channel selection buttons labeled 1, 2, 3, and 4.

#	Description
1	Buzzer Active
2	Unacknowledged Events
3	Active or Unacknowledged Events
4	Buzzer Active
5	Unacknowledged Events in Group 1
6	None
7	None
8	None

Available Functions	
Buzzer Active	Activates on any new events. Deactivates on – acknowledge of event, OR – press the Alarm button
Unacknowledged Events	Active if at least one unacknowledged event is present.

<b>Available Functions</b>	
Active or Unacknowledged Events	Active if at least one active OR at least one unacknowledged event is present.
Active or Unacknowledged Events in Group 1	Active if at least one active OR at least one unacknowledged event in group 1.
Active or Unacknowledged Events in Group 2	Active if at least one active OR at least one unacknowledged event in group 2.
Active or Unacknowledged Events in Group 3	Active if at least one active OR at least one unacknowledged event in group 3.
Active or Unacknowledged Events in Group 4	Active if at least one active OR at least one unacknowledged event in group 4.
Unacknowledged Events in Group 1	Active if at least one unacknowledged event in group 1.
Unacknowledged Events in Group 2	Active if at least one unacknowledged event in group 2.
Unacknowledged Events in Group 3	Active if at least one unacknowledged event in group 3.
Unacknowledged Events in Group 4	Active if at least one unacknowledged event in group 4.

### 5.6.2 Expansion Output Channels

Expansion output channels can be used for different functions

- User controlled
- Automated
  - Built-in functions
  - Activated when any channel event is active

The user controlled output channels are displayed on a separate page.

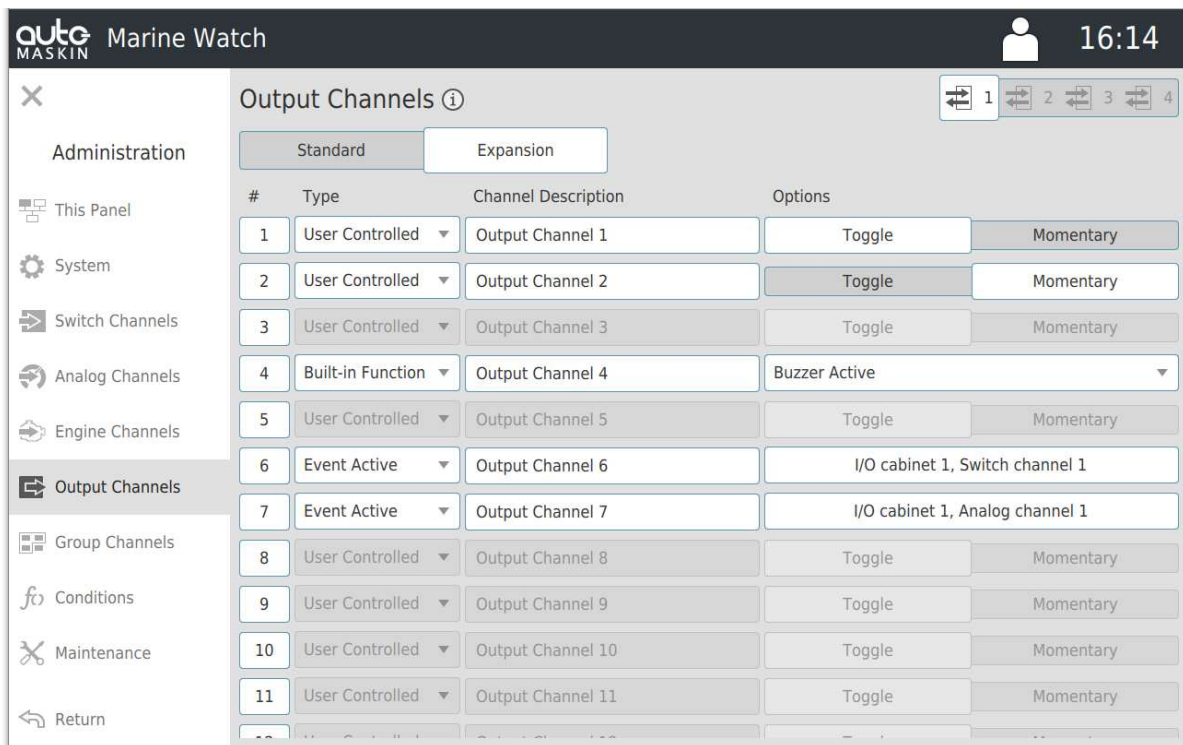

Configuration	
#	Press the channel number to enable or disable that channel.
Type	<p><b>User Controlled</b> Display the output channel on the output channel page and control it manually from the Main Panel.</p> <p><b>Built-in Function</b> Built-in functions can control the output. The functions are the same as defined in <a href="#">Standard Output Channels</a> chapter.</p>

Configuration	
	<p><b>Event Active</b> Output is activated when the selected channel event is active.</p>
Description	<p>The text that is displayed if the output is used as a user controlled output. Maximum 45 characters and four lines of text; word wrapping is performed automatically. Choose a consistent style for all the channel descriptions.</p>
Options	<p><b>Use Controlled</b> A Toggle type output channel remains in its last selected state, while a Momentary type will reset automatically.</p> <p><b>Built-in Function</b> Select the desired function.</p> <p><b>Event Active</b> Select the desired channel.</p>

## 5.7 Group Channels

Channels are by default not assigned to any group but can be assigned to any of the four available groups.

To edit this, the panel must be a Main Panel.

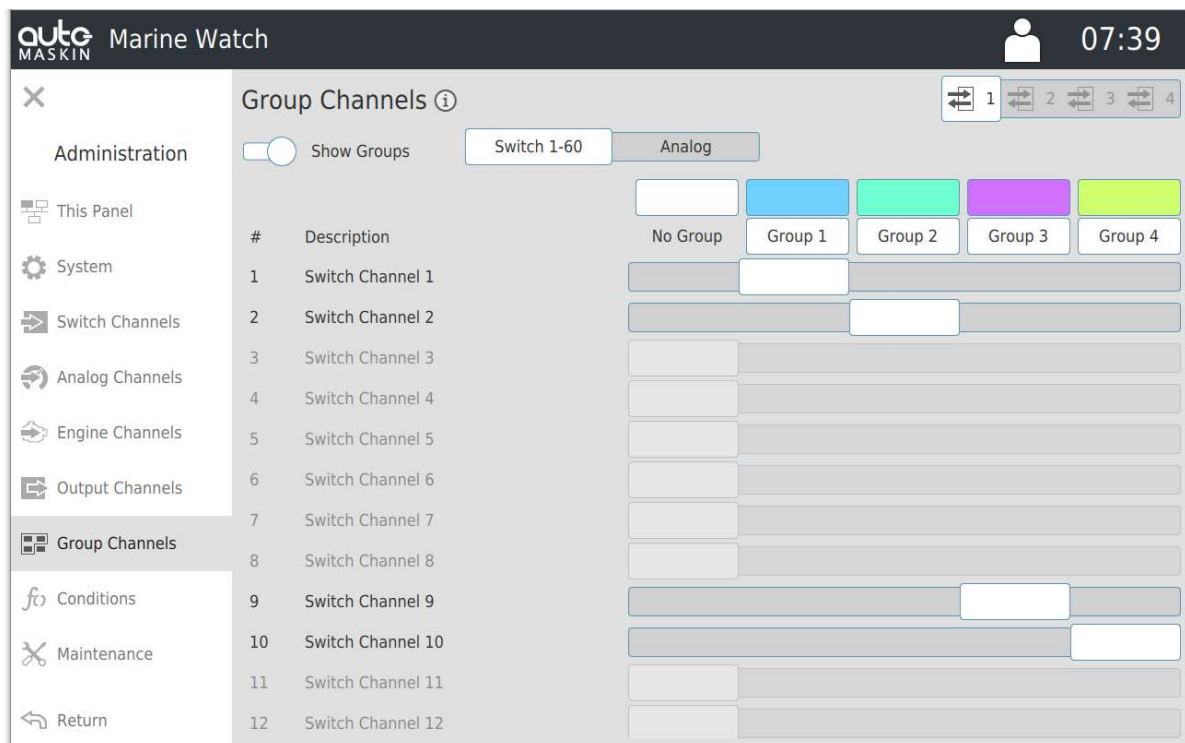

A panel can have the authority to acknowledge all channels or a select group of channels only. This is selected in the Administration menu under [This Panel](#).

Channels that are assigned to a group can only be acknowledged on panels that have selected this group. They are in a way "protected" from acknowledging, which can be done from select panels only.

Furthermore, if a channel is assigned to a group, then the group belonging can be visualised using the configured group colour in the grid/gauge view. The operator can switch this visualisation on/off.

Status	
Groups	Select which group the channel shall be assigned to. By default, all channels are unassigned. <b>Note!</b> Press the group name to change the name of that group.

## 5.8 Conditions

Configure up to 20 conditions which can be used in the channel configuration. If used in a channel configuration, the condition must be fulfilled for the channel to issue an event.

Any condition can be configured to be displayed on the Home Page.

#	Description	Home Page	Switch Channel	Must Be
1	Running	<input checked="" type="checkbox"/>	I/O Cabinet 1, Switch Channel 31	Low High
2	In Remote Mode	<input checked="" type="checkbox"/>	I/O Cabinet 1, Switch Channel 32	Low High
3	Condition 3	<input type="checkbox"/>	I/O Cabinet 1, Switch Channel 33	Low High
4	Condition 4	<input type="checkbox"/>	I/O Cabinet 1, Switch Channel 34	Low High
5	Condition 5	<input type="checkbox"/>	I/O Cabinet 1, Switch Channel 1	Low High
6	Condition 6	<input type="checkbox"/>	I/O Cabinet 1, Switch Channel 1	Low High
7	Condition 7	<input type="checkbox"/>	I/O Cabinet 1, Switch Channel 1	Low High
8	Condition 8	<input type="checkbox"/>	I/O Cabinet 1, Switch Channel 1	Low High
9	Condition 9	<input type="checkbox"/>	I/O Cabinet 1, Switch Channel 1	Low High
10	Condition 10	<input type="checkbox"/>	I/O Cabinet 1, Switch Channel 1	Low High
11	Condition 11	<input type="checkbox"/>	I/O Cabinet 1, Switch Channel 1	Low High

## 5.9 Maintenance

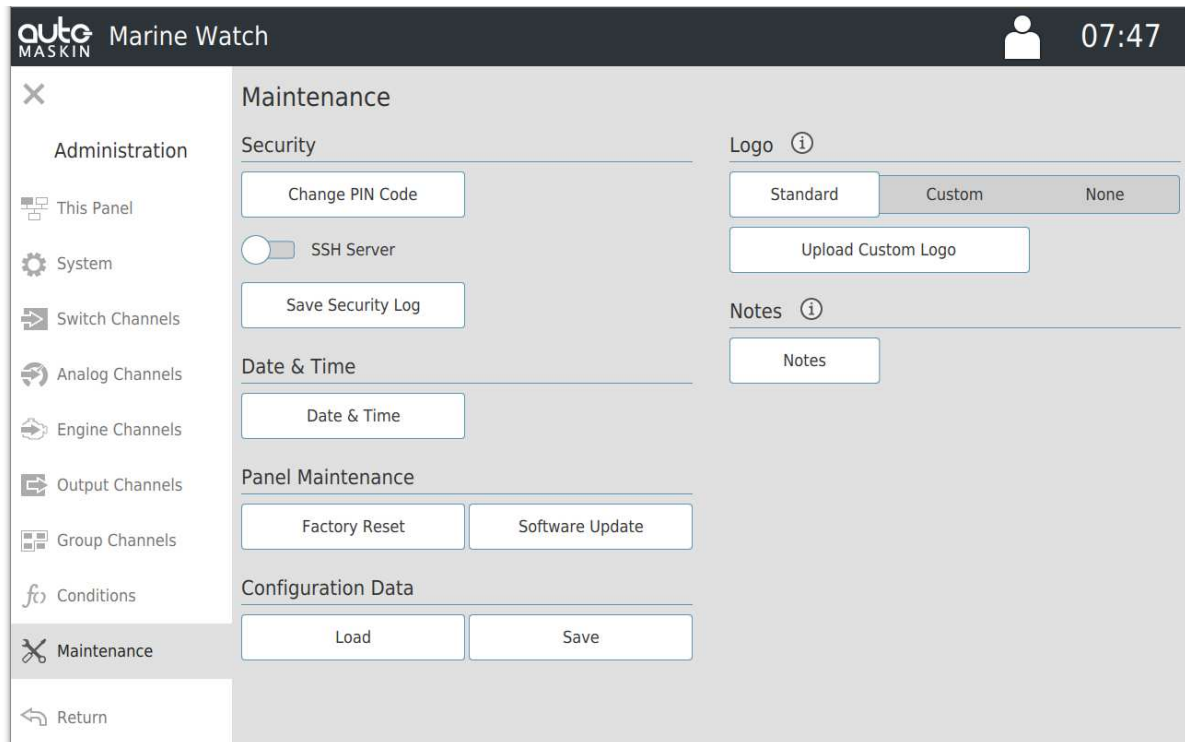

### 5.9.1 Security

#### 5.9.1.1 Change PIN Code

Dialogue for changing the active PIN code for logging in to the Administration menu. The PIN code must be 4 to 8 digits long.

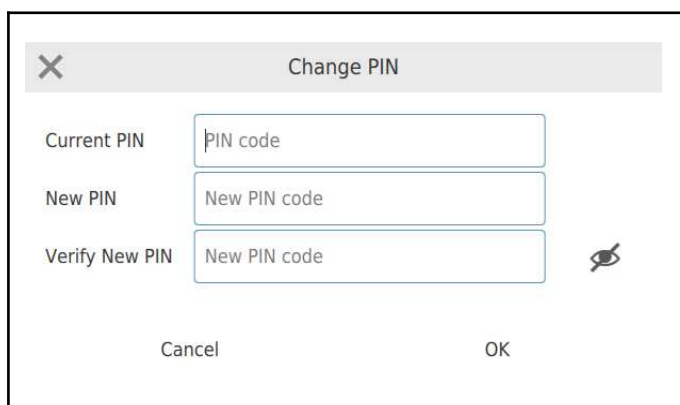

### 5.9.1.2 SSH Server

Enables a debug SSH server for this panel. A power cycle will disable the SSH server again.

### 5.9.1.3 Security Log

The security log contains events related to cyber security. In order to extract the security log, a USB stick needs to be inserted into the unit.

## 5.9.2 Date & Time

Sets the date and time of the panel.

The screenshot shows a 'Date & Time' configuration window. At the top left is a close button (X). The title is 'Date & Time'. Below the title, there are two date pickers: one for the year '2020' and one for the month 'July', each with minus and plus navigation buttons. To the right is a 'Time' section with two digit spinners (9 and 56) and AM/PM buttons. Below the date pickers is a calendar grid with days of the week (Mon to Sun) and dates (1 to 31). The date '8' is highlighted. At the bottom, there are 'Cancel' and 'OK' buttons.



A Subpanel has the option of retrieving the time from the Main Panel. This is done by selecting the **Use Time From Main Panel** switch.

## 5.9.3 Panel Maintenance

### 5.9.3.1 Factory Reset

A Factory Reset will remove and reset the following

- Configuration
- Event log
- User PIN code
- Security log

### 5.9.3.2 Software Update

Updates the software of the Alarm Panel.

Using any of the three available USB-A ports, insert a USB storage device with a software update file, `<filename>.mender`, and press the **Software Update** button to select the desired update file.



The software update process takes several minutes. Do not unplug the power supply during the update.

### 5.9.4 Configuration Data

Load a configuration file named `<configuration>.ini` into the panel from a USB storage device, or save the current configuration to a USB storage device.

Make sure the USB storage device is inserted first.

### 5.9.5 Logo

Select which logo, if any, should be presented in the header.

Logo	
Standard	The default logo.
Custom	The custom logo; can be changed.
None	No logo in the header.

#### 5.9.5.1 Upload Custom Logo

Insert a USB storage device with one or several logos, in the **png** file format. Select the Upload Custom Logo to select the desired logo to be used.

The **png** file should preferably be 64px height and less than 240px width. Any larger logo will be shrunk to fit.

## 6 The S-ACE Annunciator Panel

The S-ACE Annunciator Panel displays the events from the S-ONE Main Panel in an Alarm View. No configuration is required, other than the network configuration.





The S-ACE can be configured to show all events, or a subset of the events available in the S-ONE Main Panel, based on the group configuration.

In addition, the S-ACE indicates the channel groups as defined in the S-ONE Main Panel. This is indicated with a coloured square in the top-right of the warning/alarm rectangles.

### 6.1 Buttons

In addition to the touch-screen interface there are two buttons on the right-hand side of the panel. These are used to command the panel as described below:

Symbol	Button	Action
	Home Button	Toggle between the Alarm and Menu page.
	Alarm Button	Silence the buzzer locally on this panel only, and display the Alarm View.

### 6.2 Header Information









The header carries the following information.

- The Panel is named **Marine Watch**.
- A common warning/alarm banner. The entire centre of the header is flashing for new unacknowledged events.

- Event status symbols.
- Time, optionally displayed. The displayed time is inherited from the S-ONE Main Panel.

### 6.3 Header Status Symbols

These symbols may appear in the header bar.

			
At least one channel indicates Alarm	At least one channel indicates Warning	At least one Alarm and at least one Warning	At least one new Alarm or Warning <sup>20</sup>
			
The buzzer is sounding	Watch responsible		

### 6.4 Alarm View

The Alarm View is the main view of the S-ACE Annunciator Panel. All events are shown here in a grid format.



The Annunciator Panel can be configured to show individual groups only. This is selected in the administrative part of the Panel menu.

The events are listed in chronological order, with the newest event in the top left position. If the number of events exceeds one page, a scrollbar will automatically show.

The S-ACE Annunciator Panel indicates channel groups as defined in the S-ONE Main Panel. This is indicated with a coloured square in the top-right of the warning/alarm rectangles.



There is no option to change the group configuration on the Annunciator Panel. It inherits the configuration made in the S-ONE Main Panel.

<sup>20</sup> The red alarm banner takes precedence over the yellow warning banner

If the Annunciator Panel is not operated for one minute, the Annunciator Panel will automatically default to show the Alarm View.

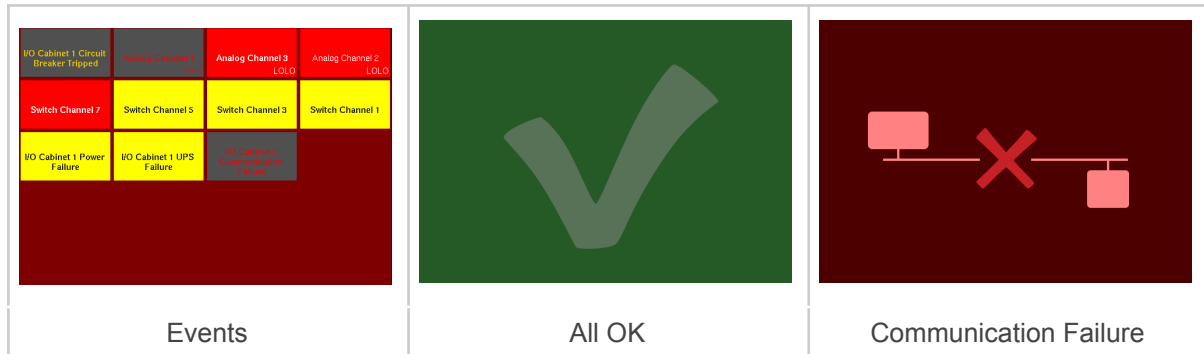

### 6.4.1 Channel Status

Each rectangle represents the status of a channel as follows.

Status	Description	Sample Graphic Representation	
Active and not acknowledged	The channel is alarming, following its persistence timer. Text in bold, flashing.		
Active and acknowledged	The channel is acknowledged by an operator and will clear when the alarm clears. Regular text.		
Inactive and not acknowledged	The channel has been activated but is not active now. It will clear when acknowledged. Grey background, bold flashing text.		

## 6.5 Menu

The menu system of the S-ACE Annunciator Panel is divided into a user menu area and an administrative menu area.

The user menu is open for the operator, and the administrative menu is locked by a selectable PIN code.

### 6.5.1 Main Menu

#### 6.5.1.1 Controls

Whenever the Main Menu is accessed, it always displays the Controls section.

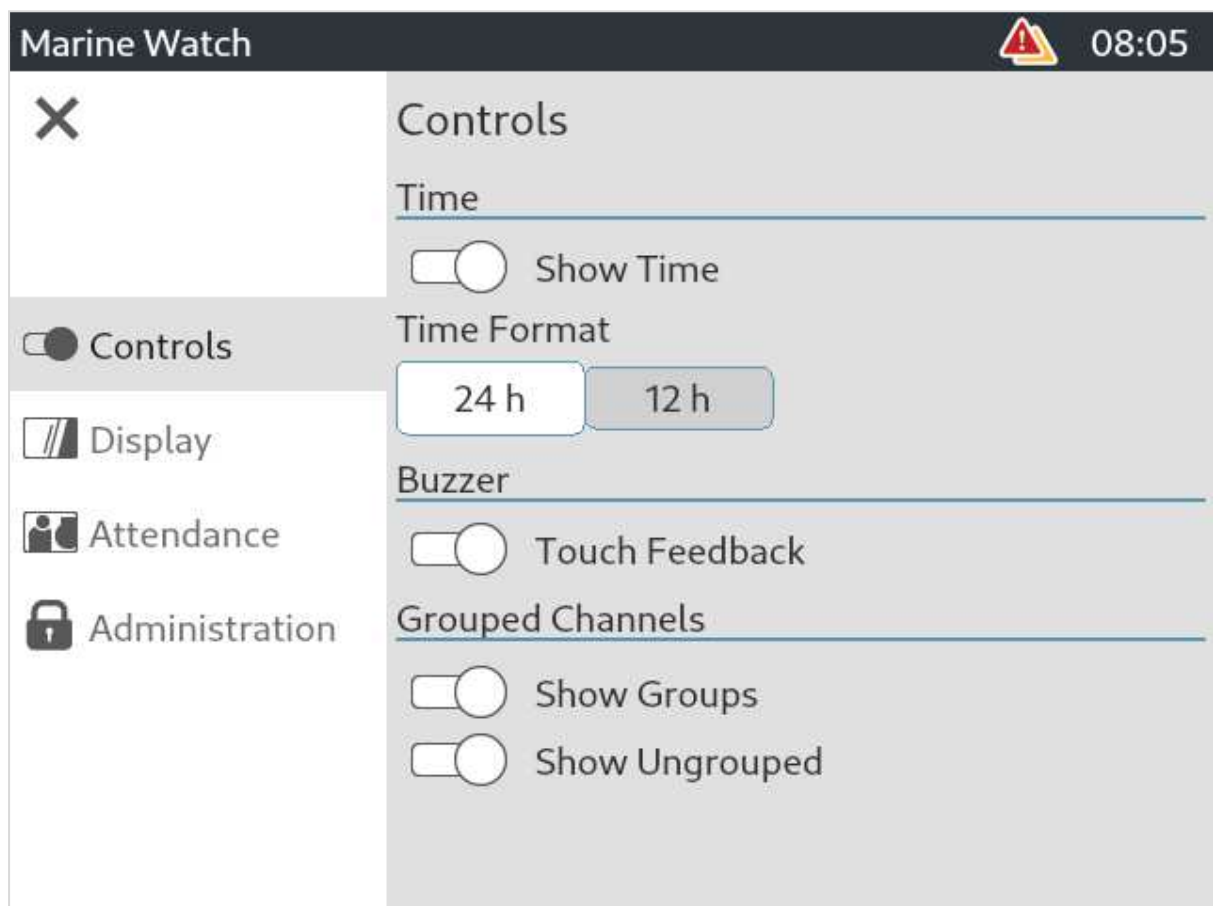

Time	
Show Time	Select whether the time shall be shown in the header.
Time Format	
24 h	Select the 24 h presentation of time, for instance, 18.42
12 h	Select the 12 h presentation of time, for instance, 6.42 PM.
Buzzer	
Touch Feedback	Select whether audible feedback is given upon touch and key button presses.
Grouped Channels	
Show Groups	Displays the channel group belonging in the alarm list.
Show Ungrouped	Displays the ungrouped channel belonging in the alarm list.

### 6.5.1.2 Display

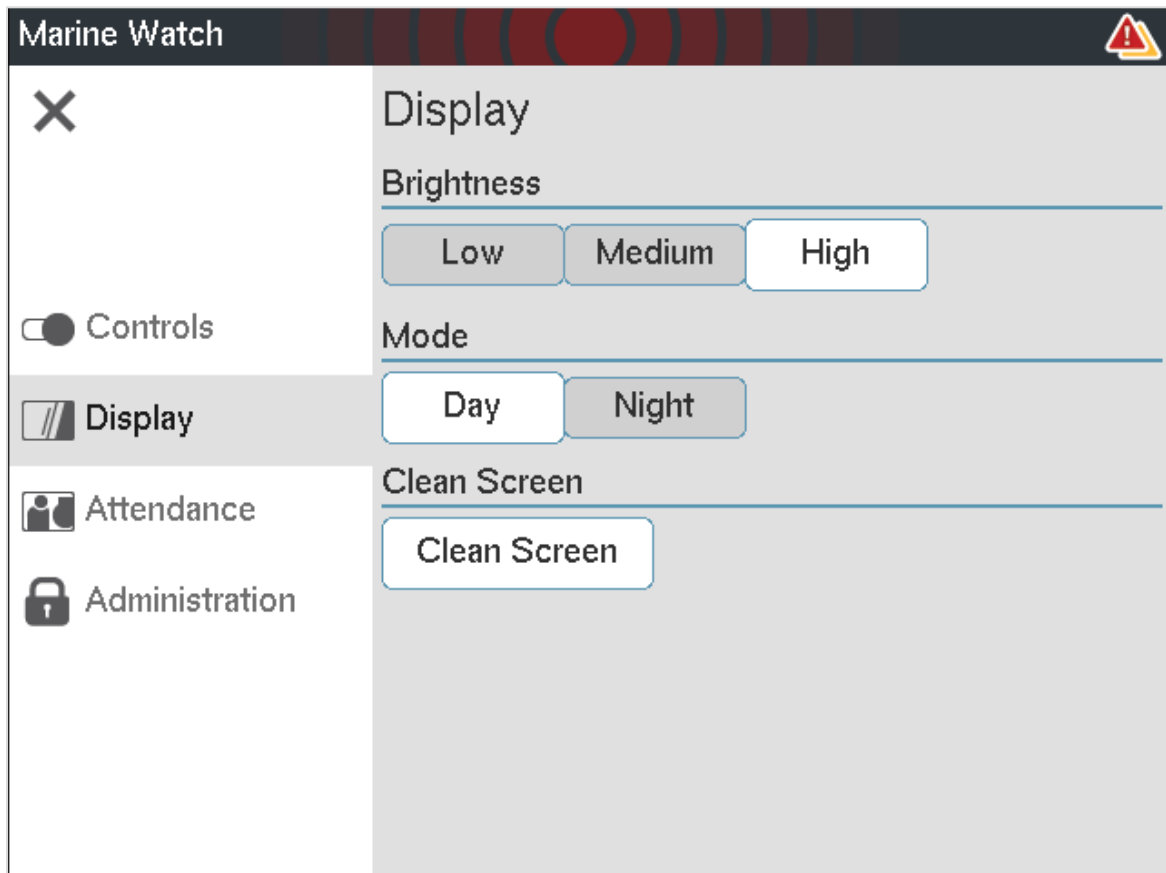

Brightness	
Low, Medium, High	Select the screen brightness
Mode	
Day	Colours optimised for daylight.
Night	Colours are optimised for use in dark environments.
Clean Screen	
Clean Screen	Displays the screen in all black so fingerprints are clearly visible and can be wiped off with a soft cloth. Press the button on the screen to exit.

### 6.5.1.3 Attendance

This menu page is only visible if the Main Panel is configured for periodically unattended engine room.

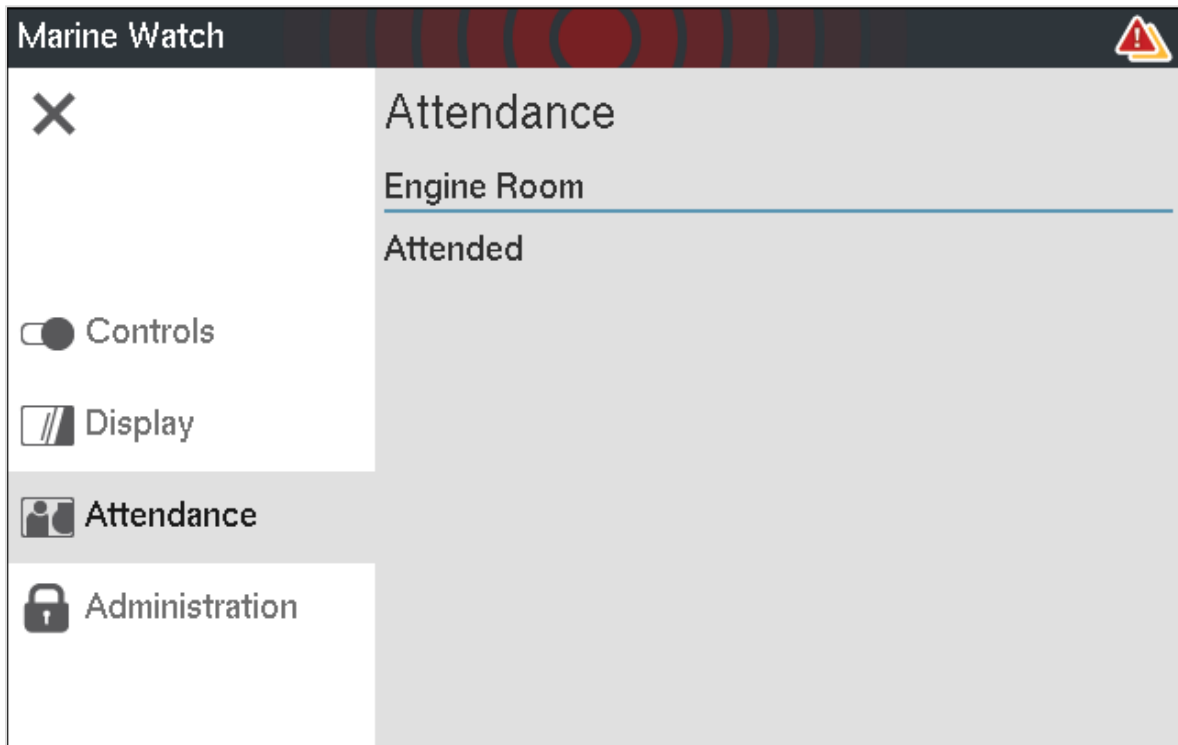

This menu page displays engine room attendance status as well as on-duty engineer.

#### 6.5.1.4 Administration

This is the login page for the Administration menu. It also displays some data as follows.

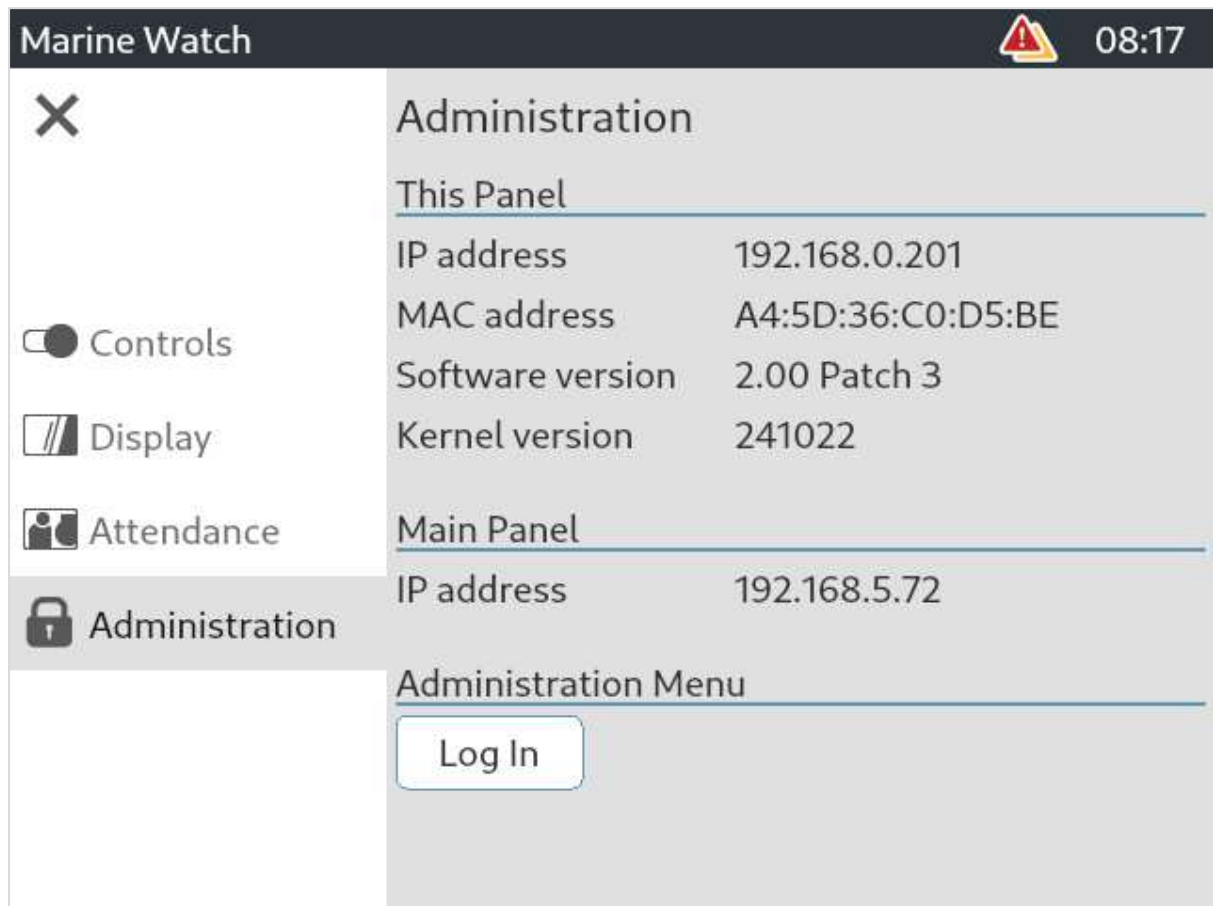

This button is the entrance to the Administration Menu.

To log in, press the **Log In** button, then add the following info into the dialogue.

- PIN code: **1234** (factory default)

If the PIN Code is lost, then your distributor can source the PIN code using the encrypted PIN code.

## 6.5.2 Administration Menu

### 6.5.2.1 This Panel

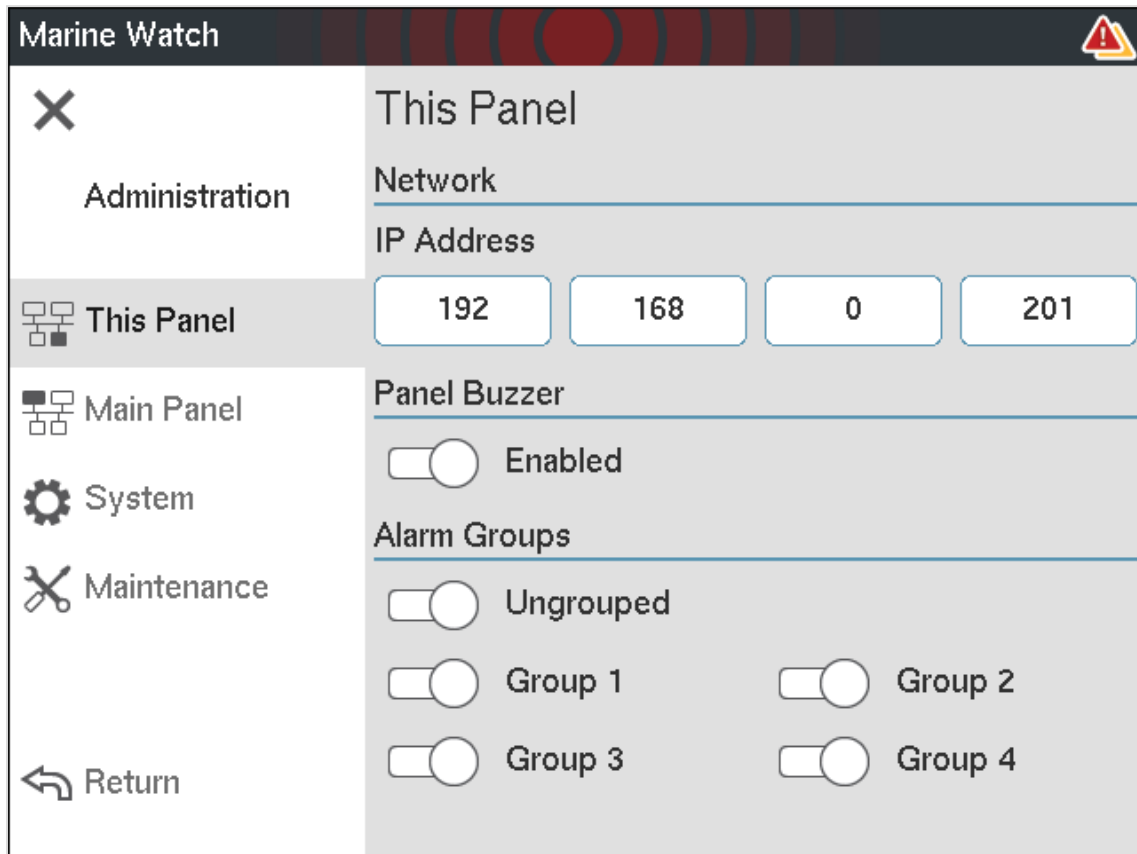

<b>Network</b>
Set the IP address of this S-ACE panel. Make sure all IP addresses in the network are unique.
<b>Panel Buzzer</b>
Enable / disable the panel buzzer for any new event.
It is possible to connect an external buzzer to the panel using connector C1.1. This is required to fulfil sound requirements in a type-approved installation.
<b>Alarm Groups</b>
Select which groups of events this S-ACE Annunciator Panel shall monitor.
 Channels that are not assigned to any group will not be displayed if the Ungrouped switch is not selected.

If a group is not selected, this S-ACE Annunciator Panel will not issue events for channels assigned to that group.

### 6.5.2.2 Main Panel

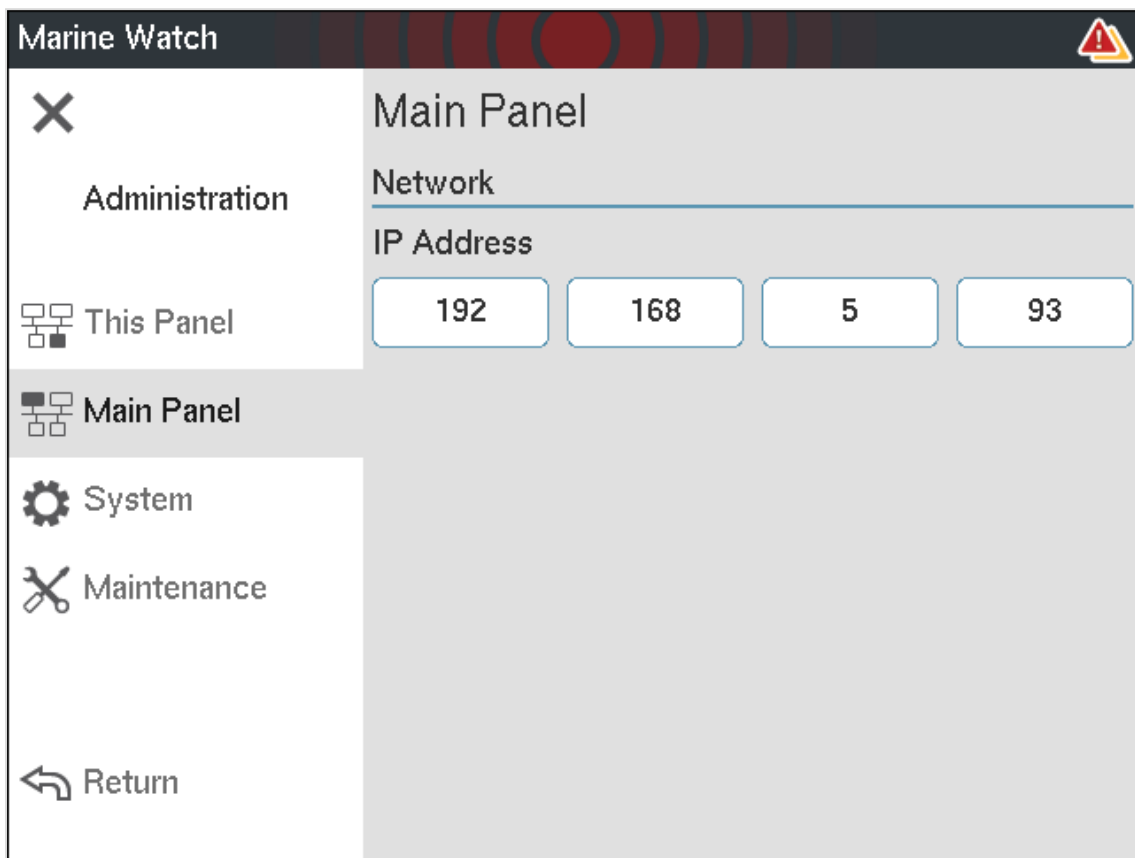

#### Network

Set the IP address of the S-ONE Main Panel.

### 6.5.2.3 System

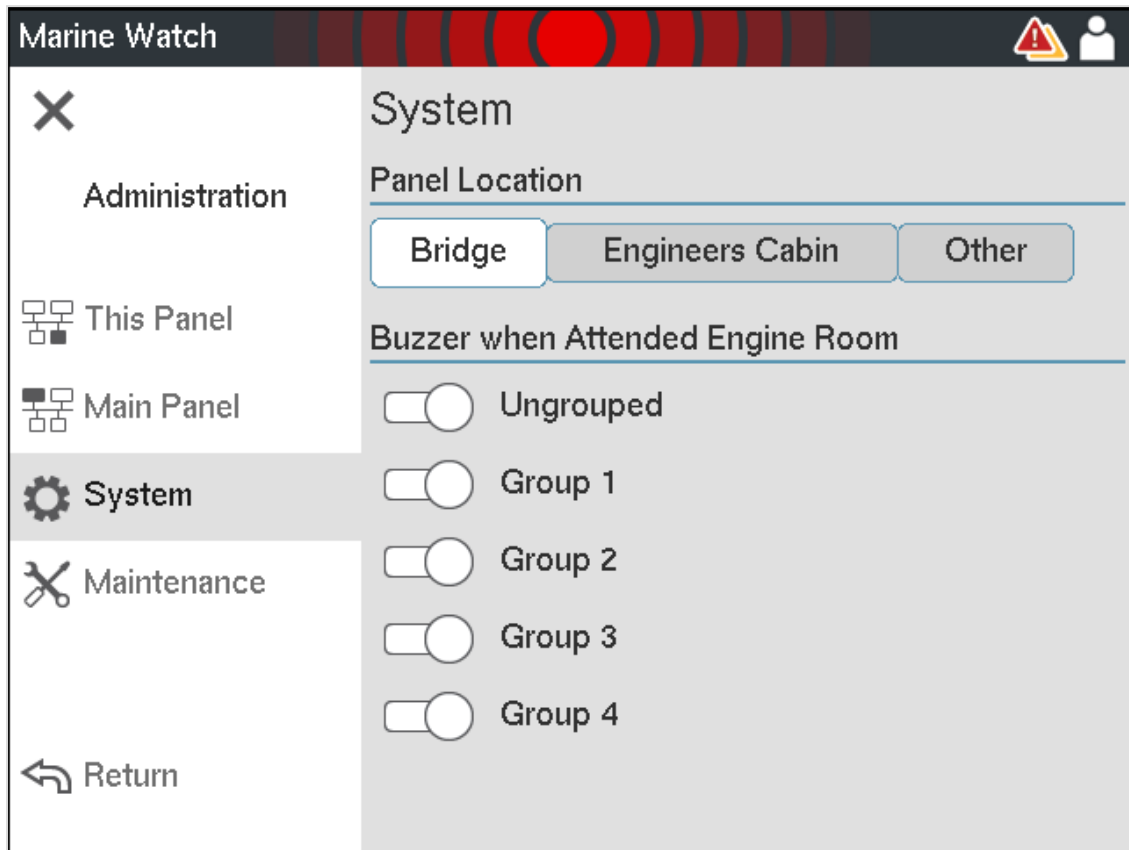

#### Panel Location

Select the panel location.

#### Buzzer when Attended Engine Room

If the **Bridge** panel location is selected, and **Periodically Unattended Engine Room** is enabled for the Marine Watch S system, the panel can be configured for which groups the buzzer shall be enabled for new events.

6.5.2.4 Maintenance

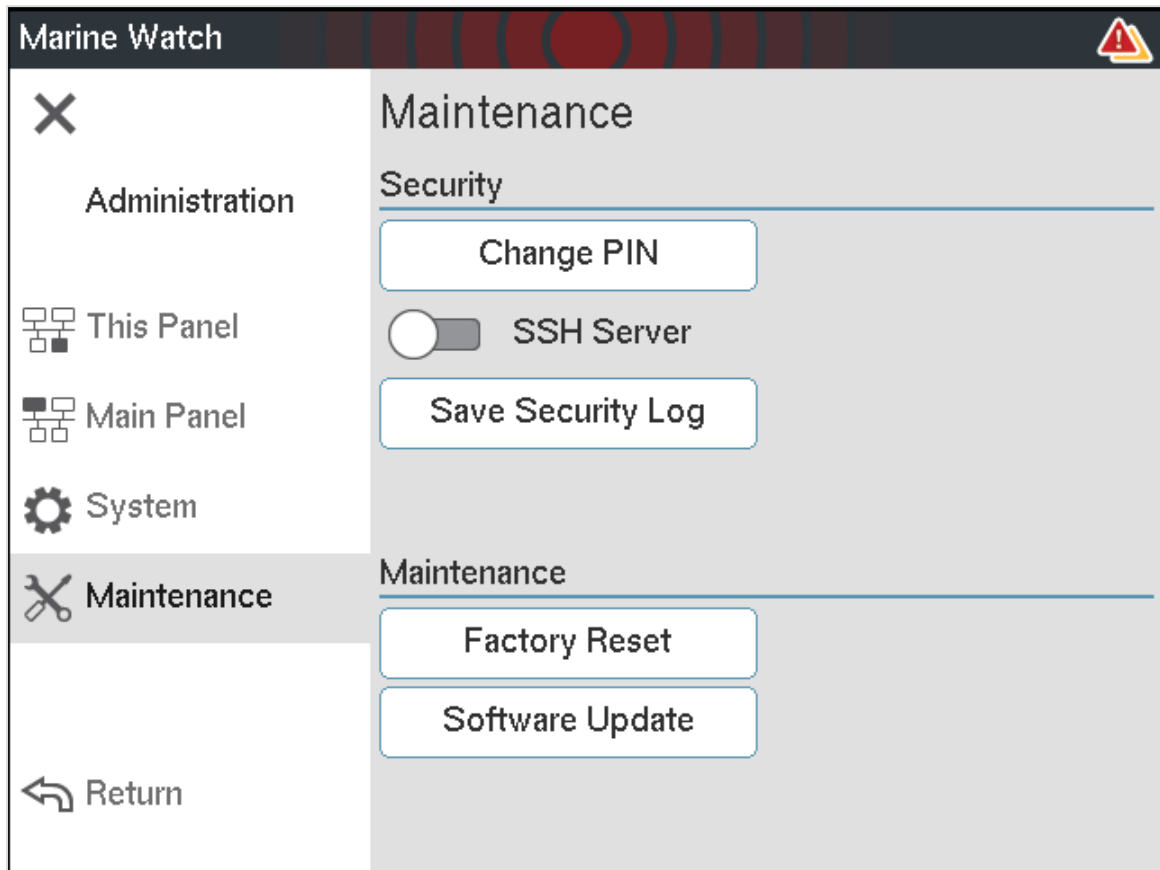

<b>Change PIN</b>
Dialogue for changing the active PIN code for logging in to the Administration menu.
<b>SSH Server</b>
Enable or disable the SSH server. This is a volatile configuration and will be disabled upon the next power cycle for released software.
<b>Save Security Log</b>
Extracts the security log to USB. The log will be named "security_log.csv". A USB memory stick needs to be inserted.
<b>Factory Reset</b>
A Factory Reset will remove and reset the following <ul style="list-style-type: none"> <li>• Configuration</li> </ul>

- User PIN code
- Security log

### Software Update

Updates the software of the Annunciator Panel.

Insert a USB storage device with a software update file, `marinewatch_sace.tar.gz`, and press the **Software Update** button to start the update.



The software update process takes several minutes. Do not unplug the power supply.

## 7 I/O Cabinet

All references below are made to the I/O Cabinet wiring diagram.



Always refer to the supplied wiring diagram for details. In case of conflicting information in the wiring diagram and this manual, then follow the wiring diagram.

### 7.1 Power Supply

The I/O Cabinet supports dual power supplies. If only one supply is being used, then connect the two supply inputs together in parallel. Use minimum 14 AWG / 2.5 mm<sup>2</sup> wire.

Supply	Circuit breaker	12/24V	0V
Main source	4Q2	Terminal 2	Terminal 4
Backup source	4Q4	Terminal 2	Terminal 4

#### 7.1.1 Ground Connection

Connect the I/O Cabinet to the ground using a cable connected to the ground bar.

#### 7.1.2 UPS Battery

If the I/O Cabinet is equipped with the optional UPS battery, it will keep the system running for 4-6 hours in case of a power supply failure.



The actual time the battery will keep the system running is depending on configuration and setup.

### 7.2 Ethernet Communication

Connect a CAT5 Ethernet cable between any of the available ports on the Ethernet Switch and an alarm panel. Multiple alarm panels can be connected.

### 7.3 Switch Channels

All switch input channels shall be connected directly to the I/O module. From the wiring diagram, locate the correct I/O module and connect as follows.

Switch input channel	Connections
1	00 – 10
2	01 – 11
3	02 – 12
etc.	...

Do prefer normally closed (NC) contacts, as then a broken wire also indicates an event.

## 7.4 Analog Channels

All analog input channels shall be connected directly to the I/O module. Connect either a 4-20 mA signal or a 0-10 V signal per channel.

From the wiring diagram, locate the correct I/O module and connect as follows.

Analog channel	0-10 V connections	4-20 mA connections
1	00 – 10	20 – 30
2	01 – 11	21 – 31
3	02 – 12	22 – 32
...	...	...
8	07 – 17	27 – 37

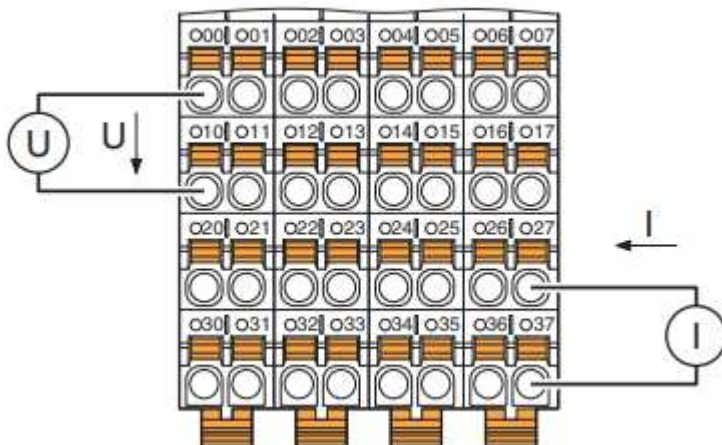

7.4.1 Analog Channel, 0 - 10 V

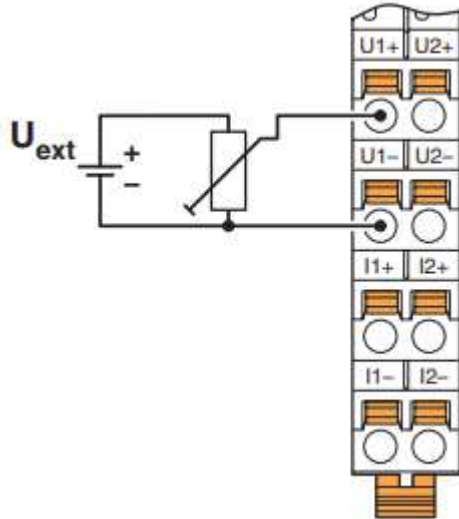

7.4.2 Analog Channel, 4-20 mA

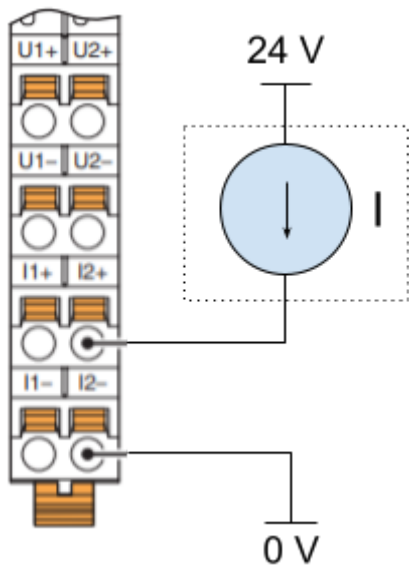

2-wire sensor

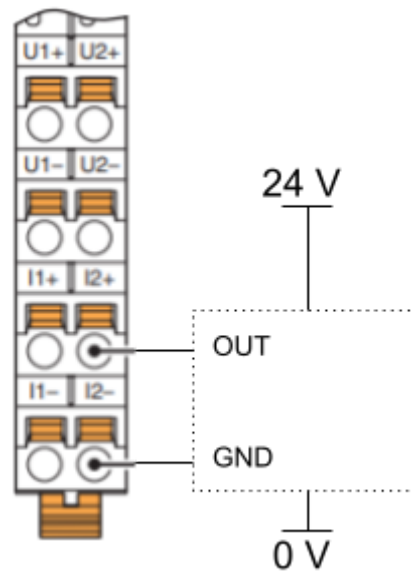

4-wire sensor

## 7.5 Output Channels

The I/O Cabinet comes with a set of standard output channels. In addition, optional output channels may be installed.

### 7.5.1 Standard Output Channels

The following output channels are always available in the I/O Cabinet.

#	Function	Connections	Description
1	Buzzer Active	00 – 10	Activates on new events.  Deactivates on – acknowledge of event, OR – press the Alarm button
2	Common Unacknowledged Events	01 – 11	Active if at least one unacknowledged event is present.
3	Common Active OR Unacknowledged Events	02 – 12	Active if at least one active OR at least one unacknowledged event is present.
4	Configurable	03 – 13	
5	Configurable	04 – 14	
6	Configurable	05 – 15	
7	Configurable	06 – 16	
8	Configurable	07 – 17	

See the [Output Channels](#) chapter for available configurable functions.

### 7.5.2 Expansion Output Channels

All switch output channels shall be connected directly to the I/O module. From the wiring diagram, locate the correct I/O module and connect as follows.

Switch output channel	Connections
1	00 – 10
2	01 – 11
3	02 – 12
etc.	...

One channel can source a maximum of 2 A. However, there is a maximum of 2 A in total for the I/O module including the standard output channels.

The optional two output I/O modules can source a maximum of 2 A in total.

## 7.6 Supply for Auxiliary Equipment

The I/O Cabinet has the circuit breaker 4Q35 (for S-C60) or 4Q36 (for S-C120) reserved for 24 V / 6 A power to one external alarm panel or one Engine Cabinet.

Additional alarm panels need a separate power arrangement.

## 8 Engine Cabinet

The optional engine cabinet can be used to interface J1939 CAN bus compatible engines. For a list of engine information shown, see [List of SPNs](#) chapter.



If the system already contains a Marine Pro system, this system can be used to interface the engine. If a Marine Pro system is used, simply connect the Marine Pro network to the Marine Watch network.

### 8.1 Wiring



Always refer to the supplied wiring diagram for details. In case of conflicting information in the wiring diagram and this manual, then follow the wiring diagram.

#### 8.1.1 Power Supply

Connect power to the Engine Cabinet from the I/O Cabinet supply output, or from a 24 V power source. Use minimum 14 AWG / 2.5 mm<sup>2</sup> wire.

I/O Cabinet	Circuit Breaker
S-C60	4Q35
S-C120	4Q36



Make sure that the power source has the same 0 V reference as the ECM.

##### 8.1.1.1 Ground Connection

Connect the Engine Cabinet to the ground using a cable connected to the ground bar.

##### 8.1.2 Ethernet Communication

Connect a CAT5 Ethernet cable between the patch panel within the Engine Cabinet and the I/O Cabinet.



The Ethernet cable can be connected directly to the Ethernet switch in the S-C4E cabinet, or directly to the DCU in the S-C2E cabinet.

### 8.1.3 J1939 Communication

Connect the J1939 networks to the Engine Cabinet using a twisted shielded CAN bus cable.



The shield should be connected at one end only.

Make sure that the J1939 CAN bus stubs are as short as possible, maximum 30 cm.

Engine Cabinet	Interface	Shield	Low	High
S-C2E	1	X1:3	X1:4	X1:5
	2	X1:6	X1:7	X1:8
S-C4E	1	X1:5	X1:6	X1:7
	2	X1:8	X1:9	X1:10
	3	X1:11	X1:12	X1:13
	4	X1:14	X1:15	X1:16