

Marine Pro 200 Series

DCU 210E Engine Controller



At a glance

- 19 flexible I/O channels configurable for either digital input, digital output, 4-20mA input or 0-5V input
- 2 thermistor / PT-100 input channels
- Dual J1939 interfaces, embedded SPN library with translation to Modbus
- 1 magnetic pickup channel
- 1GHz dual core CPU for lightning response
- High resolution 5.7" touchscreen suitable for use with gloves
- Ethernet and Modbus communication
- IP56 front and back

Why customers choose the DCU 210E

- 13 languages selectable by one touch at any station
- Accepts multiple sensor standards
- Direct interface with ECM reduces complexity and technical risk
- Ethernet "Plug & Play" connectivity for remote panels
- Configurable engine control logic including auto and multiple start attempts
- No special tools or cables – USB port for "One Touch" updates



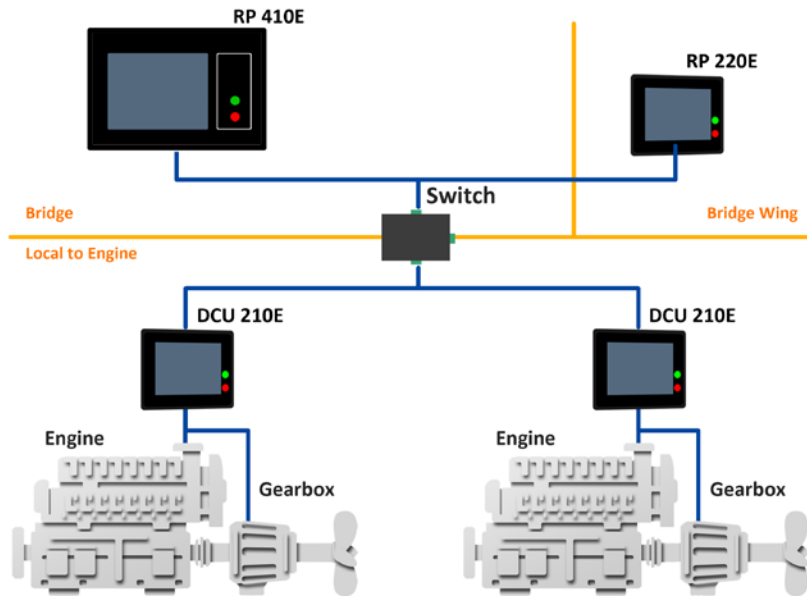

Features and benefits



Same hardware
for many
applications

Can hold more than 40
customer selectable
configuration files

Connectable to
multiple engine types
and or ships systems

Suitable for fixed
and variable speed
applications

Multiple standard I/O's
and outputs



No specialist
skills required

13 languages as stan-
dard including Chinese
and Russian

No special tools

No special software, just
an internet browser

Single unit simpler than
gauges and a CAN
reader



Cost
Effective

Integrated display and
logic eliminates wiring
faults

Can link with SDU
units to form Restricted
Class solutions

Mix and match with RIO
units for reduced cost
vessel systems



Accountability

Secure historical event
and alarm list

Displays J1939 faults
in real text

Can link to third
party systems

New screen provides
clear precise
information to operator

Ordering info

Item	Part number
DCU 210E Engine Controller	1006475
DCU 208E Engine Controller	1006477
RP 410E Remote Panel	1006476
RP 220E Remote Panel	1006472
Ethernet Switch	1050165

Sales EMEA and Asia

Phone: (+47) 64 84 52 00
Email: sales@auto-maskin.com

Sales North and South America

Phone: +1 (832) 738-1024
Email: sales.us@auto-maskin.com

Managing Energy

www.auto-maskin.com